

# Datasheet F-221MI

## MFC for High-Pressure / High- $\Delta P$ Applications, Industrial Design

### > Introduction

Bronkhorst® model F-221MI Mass Flow Controllers (MFCs) are designed for high (differential) pressure applications up to 200 bar, and suited for precise control of virtually all conventional process gases. The MFC consists of a thermal mass flow sensor, direct-acting, high-pressure control valve and a microprocessor based PID controller with signal and fieldbus conversion. As a function of a setpoint value, the flow controller swiftly adjusts the desired flow rate. The IN-FLOW model is of rugged design (IP65) for use in industrial environments or even Zone 2 hazardous areas, with optional ATEX Cat. 3 approval. The mass flow, expressed in normal litres or millilitres per minute or per hour, is provided as analog signal or digitally via RS232 or fieldbus. The flow range, wetted materials and orifice size for the control valve are determined depending of the type of gas and the process conditions of the application.

### > Technical specifications

#### Measurement / control system

|                                                             |                                                                            |
|-------------------------------------------------------------|----------------------------------------------------------------------------|
| Accuracy (incl. linearity)<br>(Based on actual calibration) | : $\pm 0,5\%$ Rd plus $\pm 0,1\%$ FS                                       |
| Turndown                                                    | : 1 : 50                                                                   |
| Multiple fluid capability                                   | : storage of max. 8 calibration curves                                     |
| Repeatability                                               | : $< \pm 0,2\%$ Rd                                                         |
| Settling time (controller)                                  | : typical 2 seconds                                                        |
| Control stability                                           | : $\leq \pm 0,1\%$ FS (typical for 1 l <sub>n</sub> /min N <sub>2</sub> )  |
| Max. Kv-value                                               | : $1,5 \times 10^{-3}$                                                     |
| Min. $\Delta P$                                             | : 2 bar(d)                                                                 |
| Max. $\Delta P$                                             | : 200 bar(d)                                                               |
| Pressure sensitivity                                        | : 0,1% Rd/bar typical N <sub>2</sub> ; 0,01% Rd/bar typical H <sub>2</sub> |
| Temperature range                                           | : -10...+70°C; for ATEX cat. 3 0... 50°C                                   |
| Temperature sensitivity                                     | : zero: $< \pm 0,05\%$ FS/°C;<br>span: $< \pm 0,05\%$ Rd/°C                |
| Leak integrity (outboard)                                   | : $< 2 \times 10^{-9}$ mbar l/s He                                         |
| Preferred mounting position                                 | : horizontal                                                               |
| Warm-up time                                                | : 30 min. for optimum accuracy<br>2 min. for accuracy $\pm 2\%$ FS         |

#### Mechanical parts

|                              |                                      |
|------------------------------|--------------------------------------|
| Material (wetted parts)      | : stainless steel 316L or comparable |
| Pressure rating              | : 200 bar(g)                         |
| Pressure tested              | : 300 bar(g)                         |
| Process connections          | : compression type or face seal male |
| Seals                        | : static: Viton; plunger: FKM        |
| Ingress protection (housing) | : IP65                               |

*Although all specifications in this datasheet are believed to be accurate, the right is reserved to make changes without notice or obligation.*



IN-FLOW Mass Flow Controller model F-221MI

#### Electrical properties

|                            |                                                                                                                                          |
|----------------------------|------------------------------------------------------------------------------------------------------------------------------------------|
| Power supply               | : +15...24 Vdc $\pm 10\%$                                                                                                                |
| Power consumption          | : Supply at voltage I/O at current I/O                                                                                                   |
| (based on N/C valve)       | 15 V 290 mA 320 mA<br>24 V 200 mA 215 mA                                                                                                 |
| Extra for fieldbus:        | PROFIBUS DP: add 53 mA (15 V supply) or 30 mA (24 V supply)<br>(if applicable) DeviceNet™: add 48 mA (24 V supply)                       |
| Analog output (0...100%)   | : 0...5 (10) Vdc, min. load impedance $> 2 \text{ k } \Omega$ ;<br>0 (4)...20 mA (sourcing), max. load impedance $< 375 \text{ } \Omega$ |
| Analog setpoint (0...100%) | : 0...5 (10) Vdc, min. load impedance $> 100 \text{ k } \Omega$ ;<br>0 (4)...20 mA, load impedance $\sim 250 \text{ } \Omega$            |
| Digital communication      | : standard RS232 ; options: PROFIBUS DP, DeviceNet™, Modbus-RTU/ASCII, FLOW-BUS                                                          |

### > Ranges (based on Air)

| Model   | minimum                       | maximum                      |
|---------|-------------------------------|------------------------------|
| F-221MI | 0,3...15 ml <sub>n</sub> /min | 0,4...20 l <sub>n</sub> /min |

*Intermediate ranges are available*

## > Model number identification

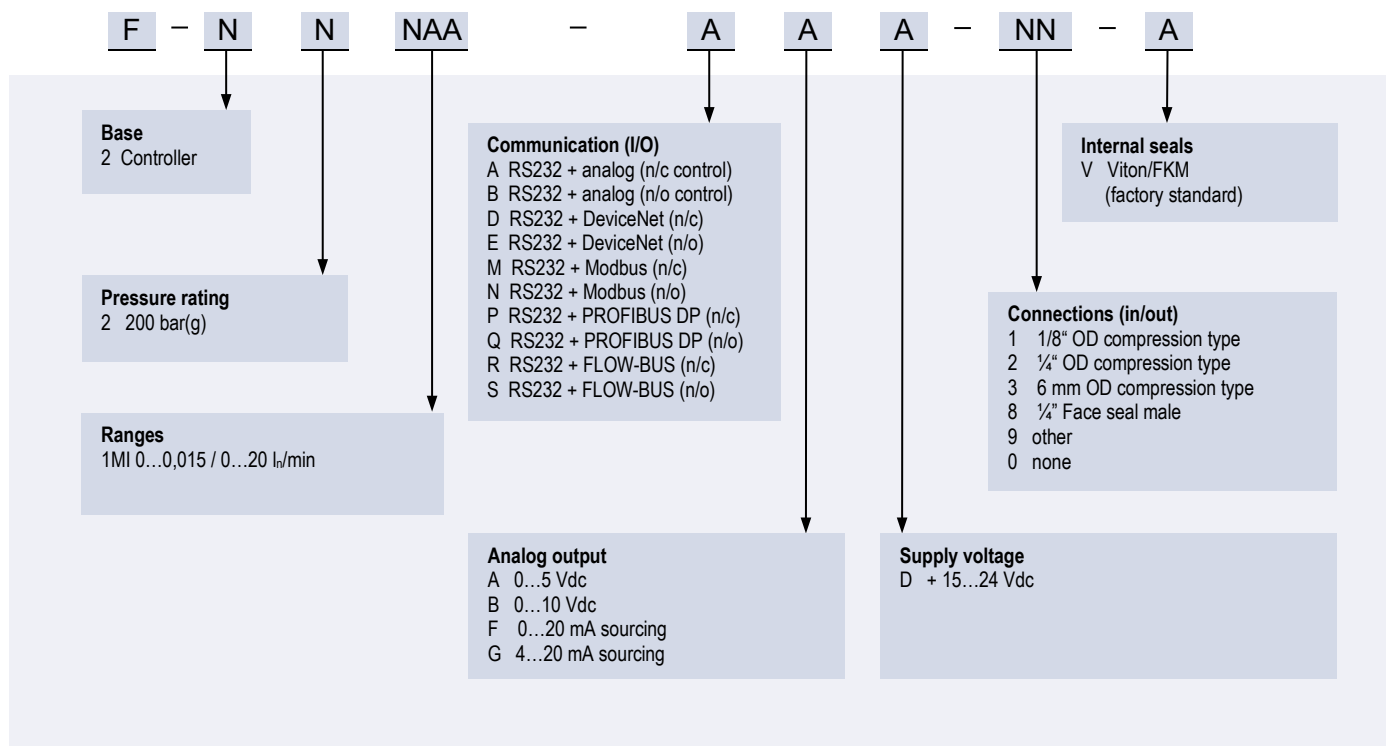

## > Thermal mass flow measuring principle

The heart of the thermal mass flow meter/controller is the sensor, which consists of a stainless steel capillary tube with resistance thermometer elements. A part of the gas flows through this bypass sensor, and is warmed up by heating elements. Consequently the measured temperatures  $T_1$  and  $T_2$  drift apart. The temperature difference is directly proportional to mass flow through the sensor. In the main channel Bronkhorst High-Tech applies a patented laminar flow element consisting of a stack of stainless steel discs with precision-etched flow channels. Thanks to the perfect flow-split the sensor output is proportional to the total mass flow rate.

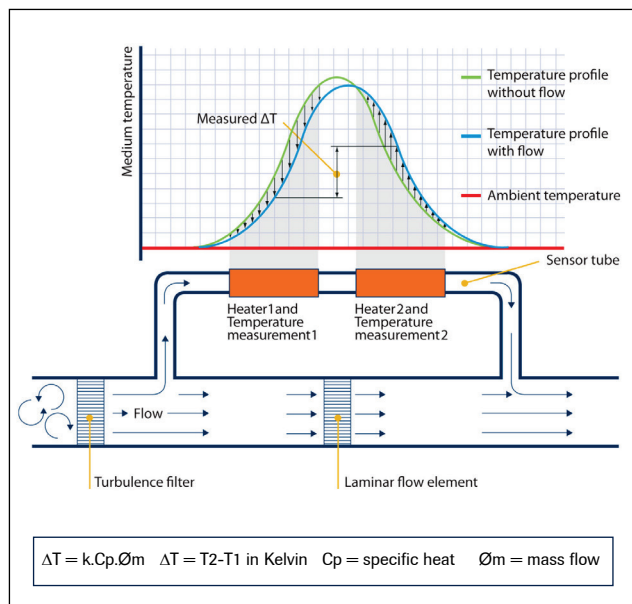

Functional scheme of the thermal mass flow sensor

## > State of the art digital design

Today's IN-FLOW series are equipped with a digital pc-board, offering high accuracy, excellent temperature stability and fast response. The basic digital pc-board contains all of the general functions needed for measurement and control. In addition to the standard RS232 output the instruments also offer analog I/O. Furthermore, an integrated interface board provides DeviceNet™, PROFIBUS DP, Modbus-RTU/ASCII or FLOW-BUS protocols.

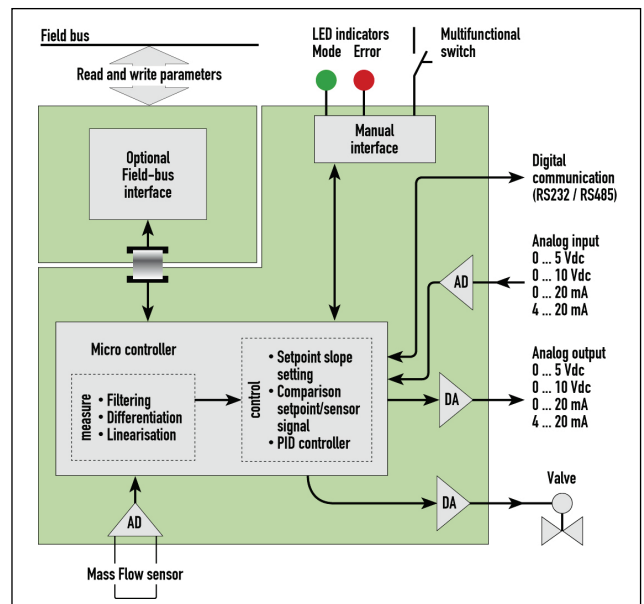

Functional scheme of the digital PC-board

## > Hook-up diagram for analog or RS232 communication

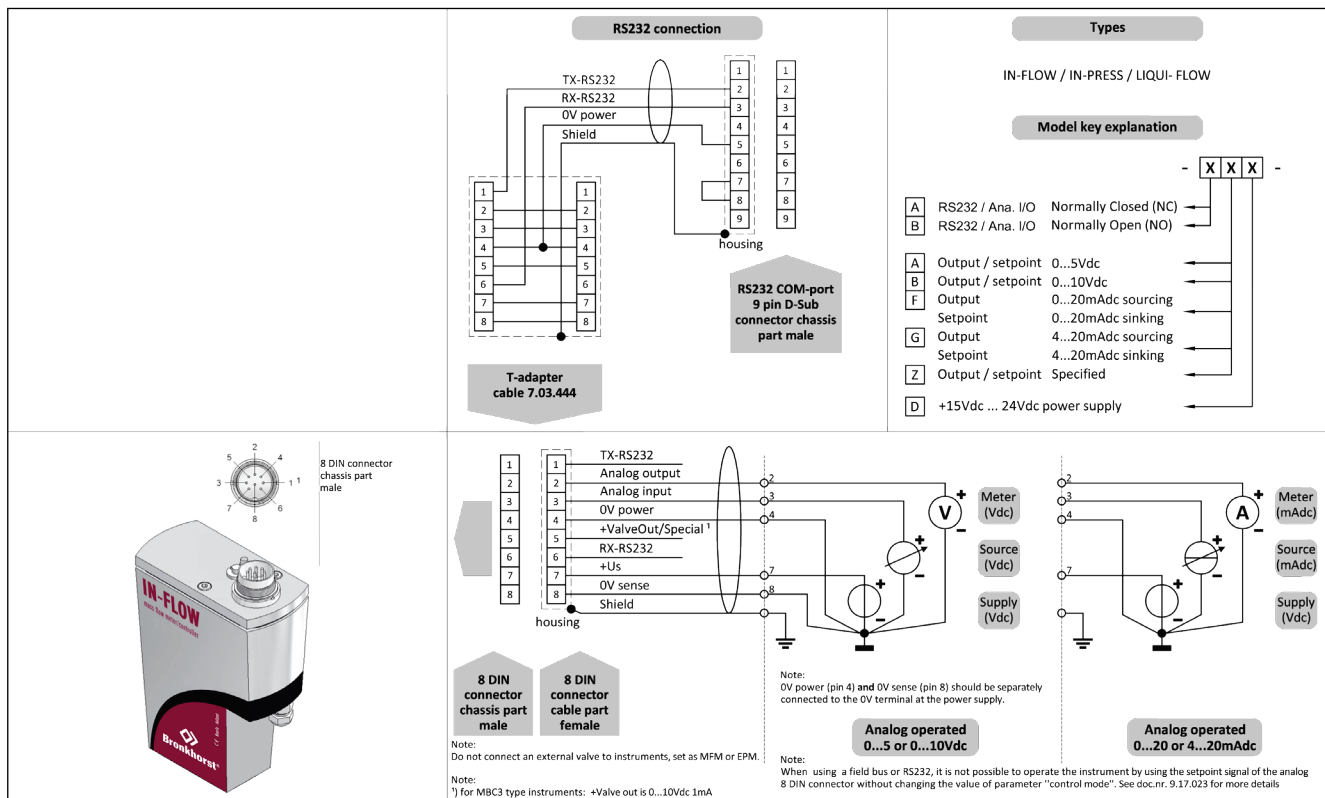

## > Hook-up diagrams for fieldbus communication

For the available fieldbus options we refer to the various hook-up diagrams as indicated below. If you are viewing this datasheet in digital format, you may use the hyperlink to each of the drawings. Otherwise please visit the download section on [www.bronkhorst.com](http://www.bronkhorst.com) or contact our local representatives.

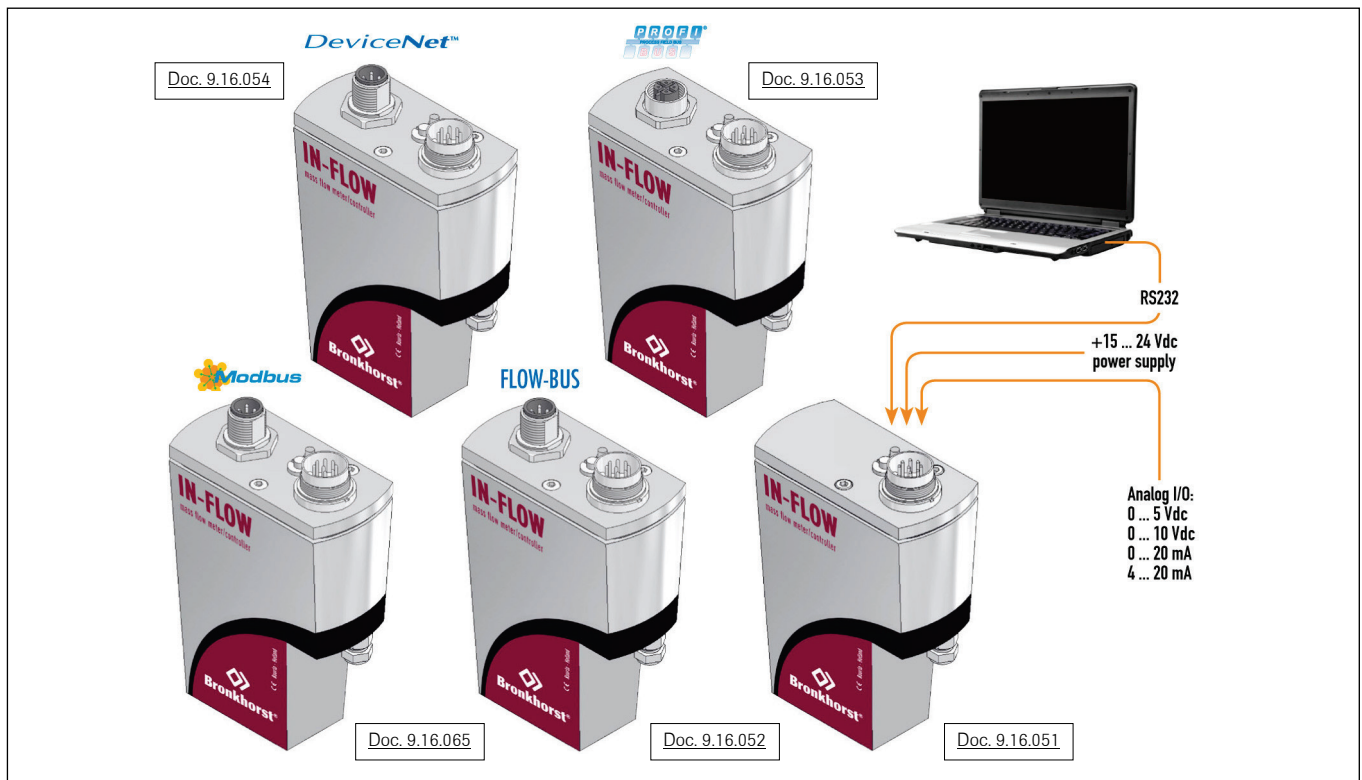

## > Dimensions (mm) and weight (kg)

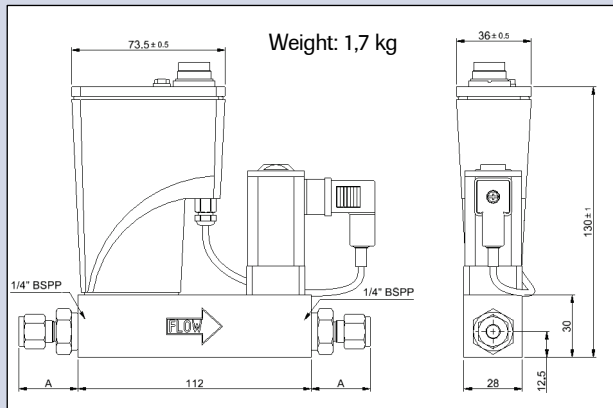

Dimension table adapters (RS-type)



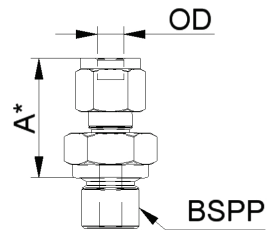

| Compression type |       | 1/4" BSPP |
|------------------|-------|-----------|
|                  |       | Size A    |
| adapter 3 mm     | OD    | 26.1      |
| adapter 6 mm     | OD    | 28.4      |
| adapter 8 mm     | OD    | 29.4      |
| adapter 10 mm    | OD    | 30.2      |
| adapter 12 mm    | OD    | 32.5      |
| adapter 1/8"     | OD    | 26.1      |
| adapter 1/4"     | OD    | 28.4      |
| adapter 3/8"     | OD    | 29.9      |
| adapter 1/2"     | OD    | 32.7      |
| Face-seal male   |       | Size A    |
| adapter 1/4"     | inlet | 23.2      |

Compression type





\*) Dimension A is typical finger-tight.

## > Options and accessories

|                                                                                                                                |                                                                                       |
|--------------------------------------------------------------------------------------------------------------------------------|---------------------------------------------------------------------------------------|
| - Free software support for operation, monitoring, optimizing or to interface between digital instruments and windows software |    |
| - IN-LINE filters for protection against particulates                                                                          |    |
| - BRIGHT compact local Readout/Control modules<br>- E-8000 Power Supply                                                        |   |
| - Interconnecting cables for power and analog/digital communication<br>- PiPS Plug-in Power Supply                             |  |

## > Alternatives

|                                                                                 |                                                                                       |
|---------------------------------------------------------------------------------|---------------------------------------------------------------------------------------|
| - PN200 EL-FLOW MFC with housing for non-industrial environment (Series F-22xM) |  |
| - PN400 IN-FLOW MFC with industrial (IP65) housing (Series F-23xMI)             |  |



# Datasheet F-23xMI

## MFC for High-Pressure / High- $\Delta P$ Applications, Industrial Design

### > Introduction

Bronkhorst High-Tech model F-23xMI Mass Flow Controllers (MFCs) are designed for high (differential) pressure applications and suited for precise control of virtually all conventional process gases. The MFC consists of a thermal mass flow sensor, a unique, high-pressure control valve and a microprocessor based PID controller with signal and fieldbus conversion. As a function of a setpoint value, the flow controller swiftly adjusts the desired flow rate. The IN-FLOW model is of rugged design (IP65) for use in industrial environments or even Zone 2 hazardous areas, with optional ATEX Cat. 3 approval. The mass flow, expressed in normal litres or millilitres per minute or per hour, is provided as analog signal or digitally via RS232 or fieldbus. The flow range, wetted materials and orifice size for the control valve are determined depending of the type of gas and the process conditions of the application.



IN-FLOW Mass Flow Controller model F-231MI

### > Technical specifications

#### Measurement / control system

|                                                             |                                                                                |
|-------------------------------------------------------------|--------------------------------------------------------------------------------|
| Accuracy (incl. linearity)<br>(Based on actual calibration) | : $\pm 0,5\%$ Rd plus $\pm 0,1\%$ FS                                           |
| Turndown                                                    | : 1 : 50                                                                       |
| Multiple fluid capability                                   | : storage of max. 8 calibration curves                                         |
| Repeatability                                               | : $< \pm 0,2\%$ Rd                                                             |
| Settling time (controller)                                  | : 2...4 seconds                                                                |
| Control stability                                           | : $\leq \pm 0,1\%$ FS (typical for 1 l <sub>n</sub> /min N <sub>2</sub> )      |
| Temperature range                                           | : -10...+70°C;<br>for ATEX Cat. 3 0...50°C                                     |
| Temperature sensitivity                                     | : zero: $< \pm 0,05\%$ FS/°C;<br>span: $< \pm 0,05\%$ Rd/°C                    |
| Leak integrity (outboard)                                   | : $< 2 \times 10^{-9}$ mbar l/s He                                             |
| Attitude sensitivity                                        | : max. error at 90° off horizontal 0,2% FS<br>at 1 bar, typical N <sub>2</sub> |
| Warm-up time                                                | : 30 min. for optimum accuracy<br>2 min. for accuracy $\pm 2\%$ FS             |

#### Mechanical parts

|                              |                                          |
|------------------------------|------------------------------------------|
| Material (wetted parts)      | : stainless steel 316L or comparable     |
| Pressure rating              | : 400 bar abs                            |
| Process connections          | : compression type or face seal male     |
| Seals                        | : Standard: Viton; options: EPDM, Kalrez |
| Ingress protection (housing) | : IP65                                   |

*Although all specifications in this datasheet are believed to be accurate, the right is reserved to make changes without notice or obligation.*

#### Electrical properties

|                            |                                                                                                                                          |
|----------------------------|------------------------------------------------------------------------------------------------------------------------------------------|
| Power supply               | : +15...24 Vdc $\pm 10\%$                                                                                                                |
| Power consumption          | : max. 320 mA;<br>add 50 mA for PROFIBUS, if applicable                                                                                  |
| Analog output (0...100%)   | : 0...5 (10) Vdc, min. load impedance $> 2 \text{ k } \Omega$ ;<br>0 (4)...20 mA (sourcing), max. load impedance $< 375 \text{ } \Omega$ |
| Analog setpoint (0...100%) | : 0...5 (10) Vdc, min. load impedance $> 100 \text{ k } \Omega$ ;<br>0 (4)...20 mA, load impedance $\sim 250 \text{ } \Omega$            |
| Digital communication      | : standard RS232 ; options: PROFIBUS DP, DeviceNet™,<br>Modbus-RTU/ASCII, FLOW-BUS                                                       |

### > Ranges (based on Air)

| Model   | minimum                       | maximum                       |
|---------|-------------------------------|-------------------------------|
| F-230MI | 0,2...10 ml <sub>n</sub> /min | 10...500 ml <sub>n</sub> /min |
| F-231MI | 10...500 ml <sub>n</sub> /min | 0,2...10 l <sub>n</sub> /min  |
| F-232MI | 0,2...10 l <sub>n</sub> /min  | 2...100 l <sub>n</sub> /min   |

*Intermediate ranges are available*



## > Model number identification

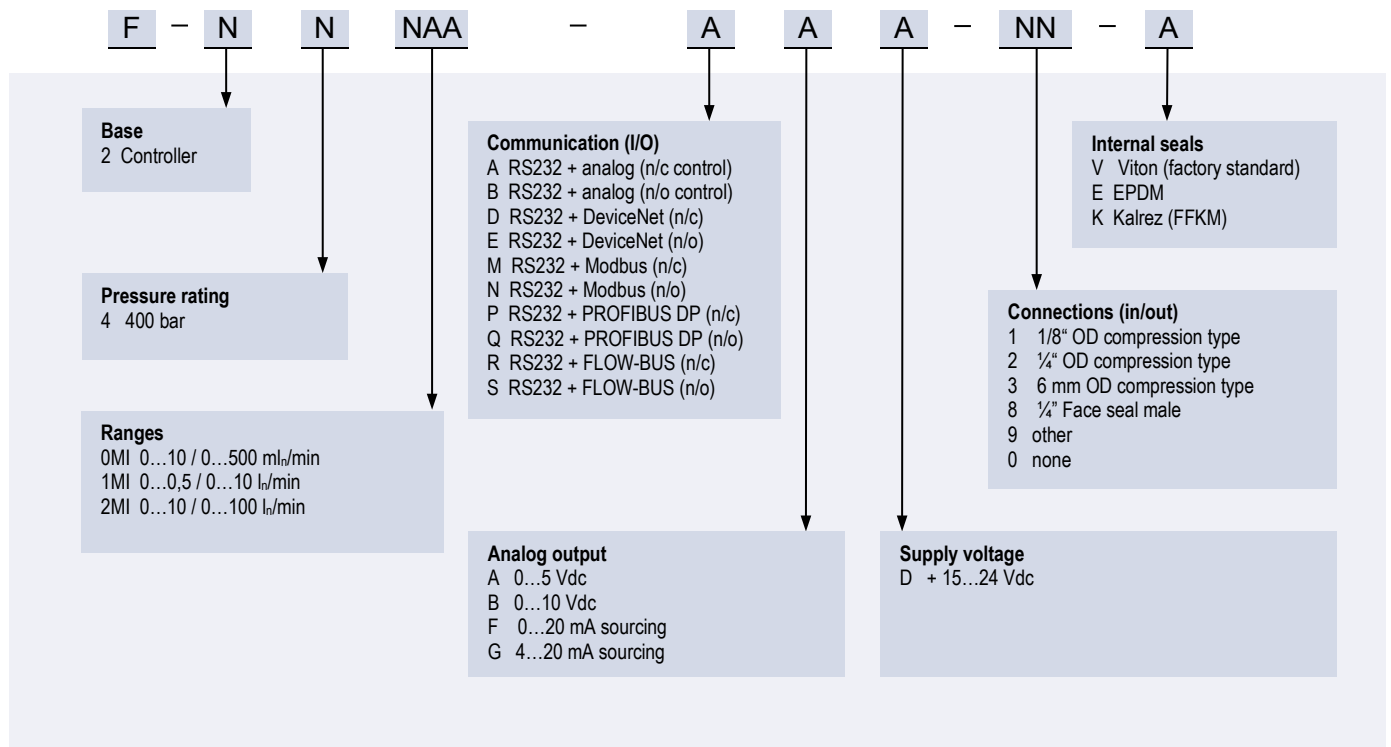

## > Thermal mass flow measuring principle

The heart of the thermal mass flow meter/controller is the sensor, which consists of a stainless steel capillary tube with resistance thermometer elements. A part of the gas flows through this bypass sensor, and is warmed up by heating elements. Consequently the measured temperatures  $T_1$  and  $T_2$  drift apart. The temperature difference is directly proportional to mass flow through the sensor. In the main channel Bronkhorst High-Tech applies a patented laminar flow element consisting of a stack of stainless steel discs with precision-etched flow channels. Thanks to the perfect flow-split the sensor output is proportional to the total mass flow rate.

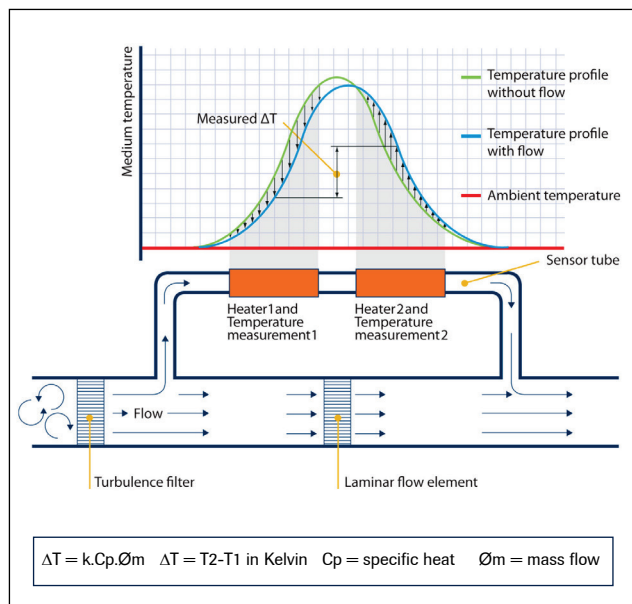

Functional scheme of the thermal mass flow sensor

## > State of the art digital design

Today's IN-FLOW series are equipped with a digital pc-board, offering high accuracy, excellent temperature stability and fast response (settling times  $t_{98}$  down to 500 msec). The basic digital pc-board contains all of the general functions needed for measurement and control. In addition to the standard RS232 output the instruments also offer analog I/O. Furthermore, an integrated interface board provides DeviceNet™, PROFIBUS DP, Modbus-RTU/ASCII or FLOW-BUS protocols.

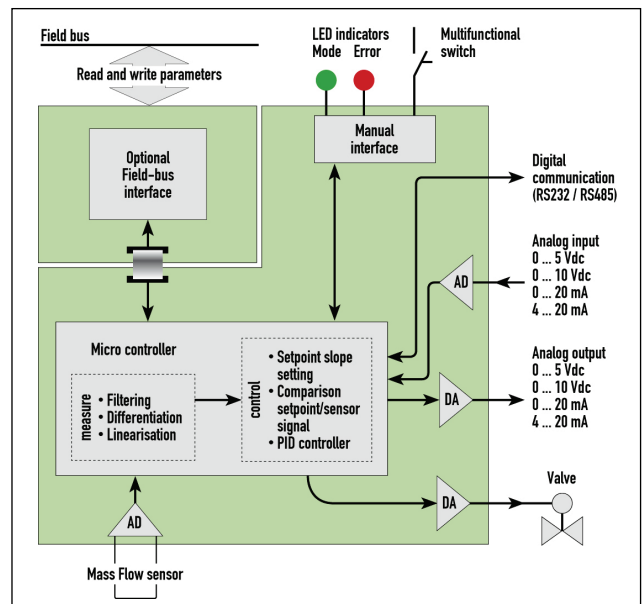

Functional scheme of the digital PC-board

## > Hook-up diagram for analog or RS232 communication

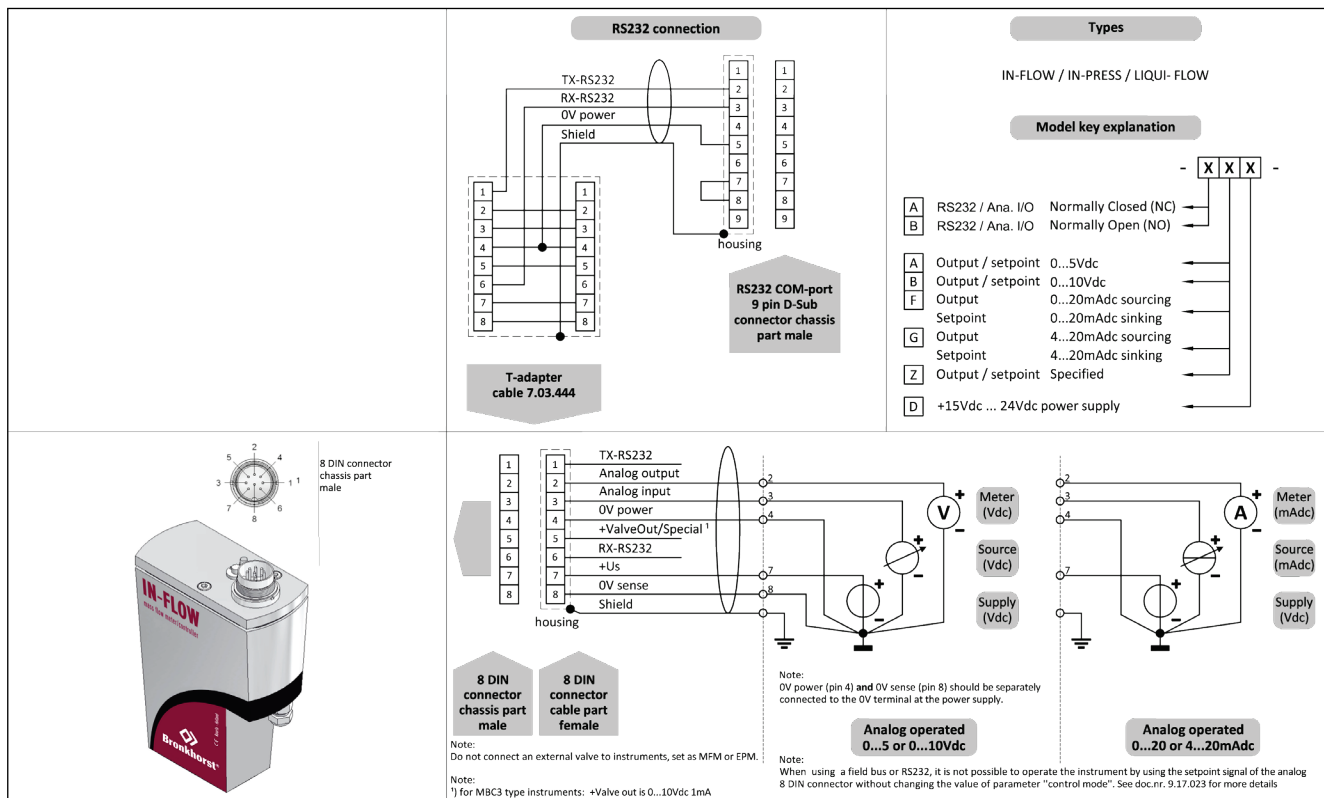

## > Hook-up diagrams for fieldbus communication

For the available fieldbus options we refer to the various hook-up diagrams as indicated below. If you are viewing this datasheet in digital format, you may use the hyperlink to each of the drawings. Otherwise please visit the download section on [www.bronkhorst.com](http://www.bronkhorst.com) or contact our local representatives.

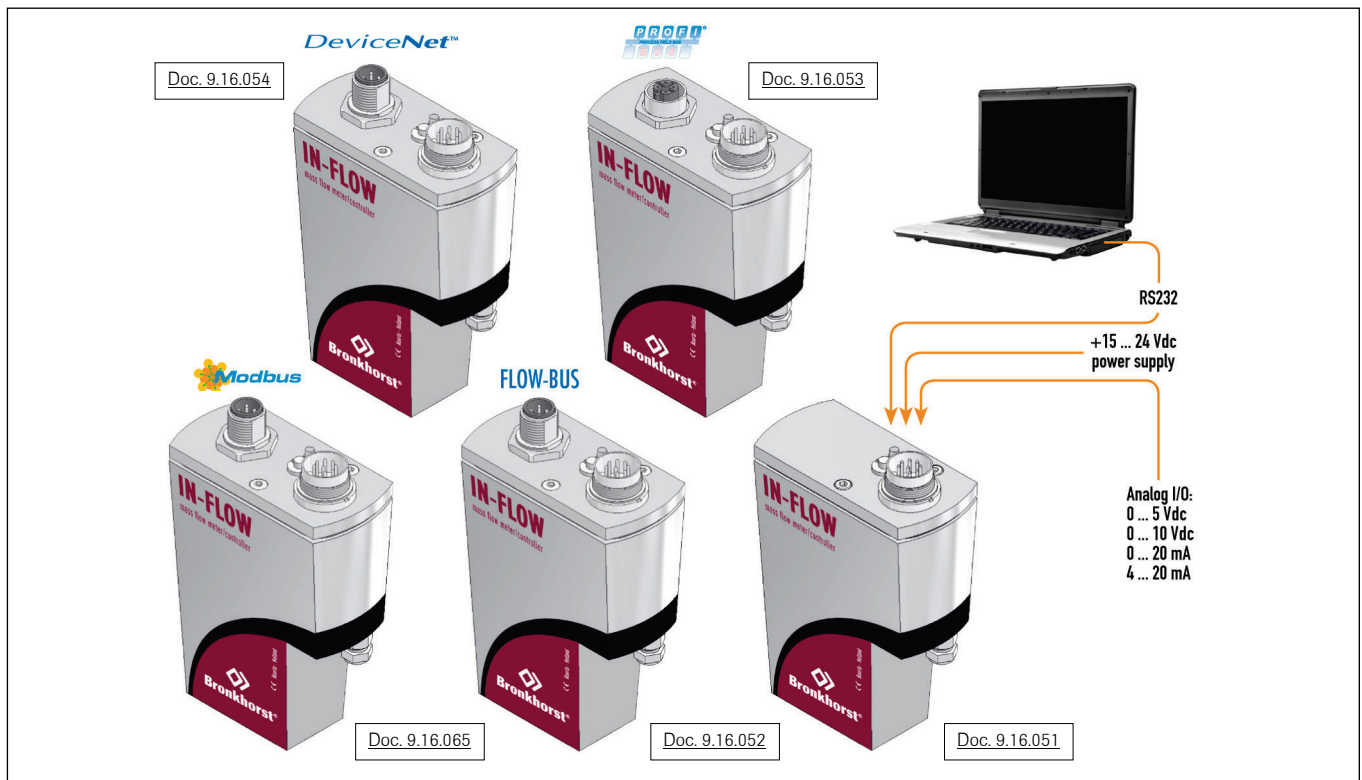

## > Dimensions (mm) and weight (kg)

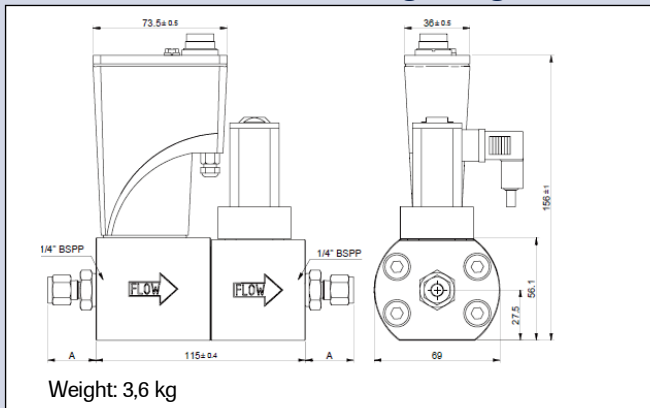

Dimension table adapters (RS-type)

| Compression type |       | 1/4" BSPP |
|------------------|-------|-----------|
|                  |       | Size A    |
| adapter 3 mm     | OD    | 26.1      |
| adapter 6 mm     | OD    | 28.4      |
| adapter 8 mm     | OD    | 29.4      |
| adapter 10 mm    | OD    | 30.2      |
| adapter 12 mm    | OD    | 32.5      |
| adapter 1/8"     | OD    | 26.1      |
| adapter 1/4"     | OD    | 28.4      |
| adapter 3/8"     | OD    | 29.9      |
| adapter 1/2"     | OD    | 32.7      |
| Face-seal male   |       | Size A    |
| adapter 1/4"     | inlet | 23.2      |

Compression type

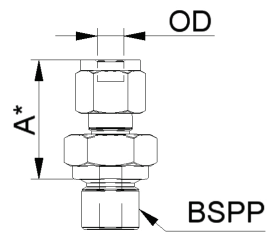

\*) Dimension A is typical finger-tight.

## > Options and accessories

|                                                                                                                                |  |
|--------------------------------------------------------------------------------------------------------------------------------|--|
| - Free software support for operation, monitoring, optimizing or to interface between digital instruments and windows software |  |
| - IN-LINE filters for protection against particulates                                                                          |  |
| - BRIGHT compact local Readout/Control modules<br>- E-8000 Power Supply                                                        |  |
| - Interconnecting cables for power and analog/digital communication<br>- PiPS Plug-in Power Supply                             |  |

## > Alternatives

|                                                                                 |  |
|---------------------------------------------------------------------------------|--|
| - PN400 EL-FLOW MFC with housing for non-industrial environment (Series F-23xM) |  |
|---------------------------------------------------------------------------------|--|



**Bronkhorst**<sup>®</sup>

Bronkhorst High-Tech B.V. Nijverheidsstraat 1a, NL-7261 AK Ruurlo The Netherlands  
 T +31 (0)573 45 88 00 F +31 (0)573 45 88 08 I www.bronkhorst.com E info@bronkhorst.com