

Type TK1, TK4 and TK4i

Patented fuelling nozzles TK1 Slow Fill TK4 Fast Fill TK4i for Italian standard

The **TK1** fuelling nozzle is designed specifically for time filling of vehicles with 'Fuelmaker' compressors. The nozzle is best suited for this application.

TK4 differs from type TK1 only by a higher flow rate, thus being designed for fast filling.

The new TK1 and TK4 fuelling nozzles are far more easy to operate. The clamping jaws are opened when the nozzle is disconnected and the sliding sleeve need not being pulled back to connect the nozzle.

This 'push to connect' feature makes even difficult-

to-access receptacles easy to refuel due to the extended construction of the nozzle.

Features:

- Compatible with the NGV1 receptacle profile (TK1/TK4)
- Compatible with the Italian receptacle profile (TK4i)
- Push-Pull actuation
- Plastic thermal protection
- WEH-JAW locking mechanism
- High-grade materials - corrosion resistant
- Integrated shut-off valve
- Compact design

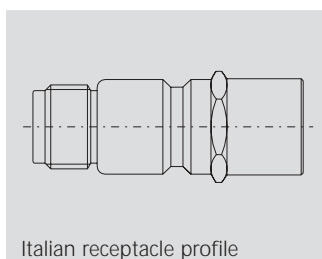

Italian receptacle profile

Innovation! The fuelling nozzle type **TK4i** has been designed especially for the Italian NGV market enabling to connect to the Italian receptacle with a push-pull nozzle. Functioning is the same as for type TK1/4. The jaws of the TK4i are constructed to avoid marks on the receptacle, as often realized when using ball valves.

WEH also offers appropriated adaptor nozzles (see page 36) for Italians with the new Italian standard, who have to refuel in Germany.

Filling hoses are available on request.

Function

The jaws of TK1/TK4 and TK4i fuelling nozzles clamp onto the receptacle. While the fuelling nozzle is connected, the shut-off valve in the nozzle will open. The pressure-tight connection is established.



Type TK1, TK4 and TK4i

Technical Data:

Application:

CNG Slow fill (TK1) and fast fill (TK4) of cars. Fuelling nozzle TK1/TK4 designed to be used with WEH-TN1 receptacle. Fuelling nozzle TK4i to be used with Italian profile. Operation only by specially trained personnel. No self-service operation!

Temperature range:

-40°C up to +85°C

Pressure range (NGV1):

TK1 and TK4:
B200 acc. to ISO 14469,
PN = 200 bar
PS = 300 bar
PT = 450 bar
Compatible NGV1, P30

TK4i

PN = 200 bar
PS = 300 bar
PT = 450 bar

Flow Rate:

TK1: Cv 0.5, 250 SCFM
TK4: Cv 1.1, 1500 SCFM
TK4i: Cv 1.1, 1500 SCFM

Design:

All parts corrosion-resistant steel; with plastic thermal protection. Seals natural gas compatible.

Registration:

PED 97/23/EC: CE 0036

Dimensions (mm):

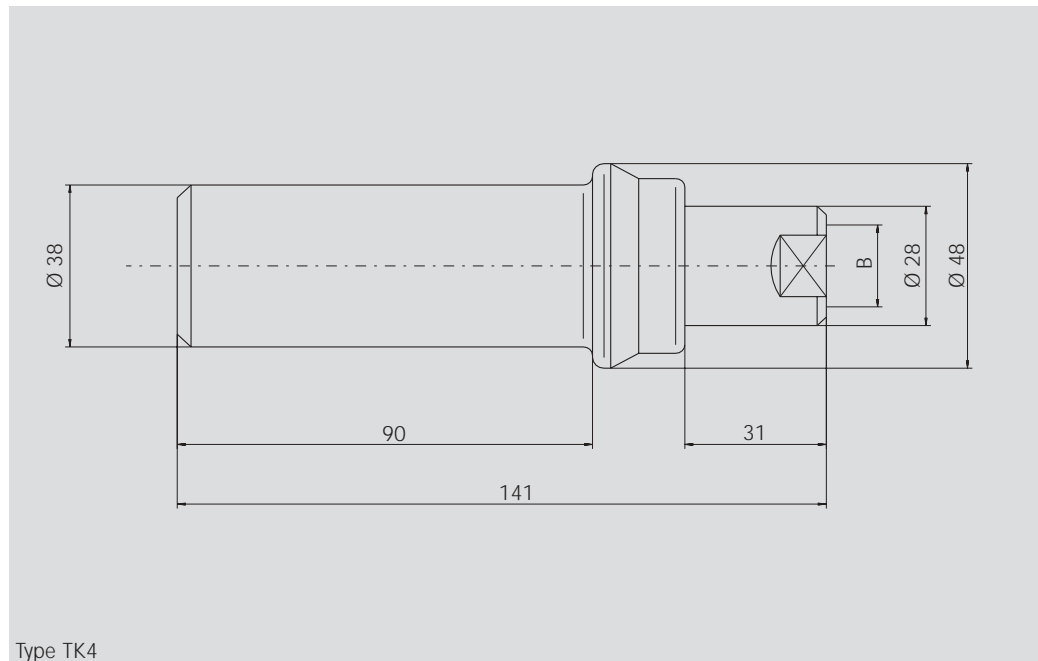

Ordering:

Inlet port 'B' for TK1/TK4 and TK4i available with other thread sizes on request.

Description	Inlet B	Part No.
TK1	UNF 9/16" - 18 internal thread / SAE-Boss*	C1-15458
TK1	UNF 9/16" - 18 left internal thread / SAE-Boss*	C1-53701
TK4	UNF 9/16" - 18 internal thread / SAE-Boss*	C1-15459
TK4	UNF 9/16" - 18 left internal thread / SAE-Boss*	C1-15501
TK4i	NPT 1/4" internal thread	C1-30943
TK4i	UNF 9/16" - 18 internal thread / SAE-Boss*	C1-17901

* acc. to SAE J1926

Manufacturer:
WEH GmbH
Gas Technology

Siemensstraße 5
89257 Illertissen/Germany

Phone: +49 7303 95190-0
Fax: +49 7303 95190-9999

Email: sales@weh.com
http://www.weh.com