

44-4700 Series

Regulators - Relief / Backpressure

D44471777X012

Specifications

For other materials or modifications, please consult TESCOM.

OPERATING PARAMETERS

Pressure rating per criteria of ANSI/ASME B31.3

Maximum Inlet Pressure

- 50 mm Hg absolute - 15 psig / 1 bar
- 50 mm Hg absolute - 50 psig / 3.4 bar
- 50 mm Hg absolute - 100 psig / 6.9 bar
- 50 mm Hg absolute - 150 psig / 10.3 bar

Design Proof Pressure

150% maximum rated

Leakage

Internal: Bubble-tight

External: $\leq 2 \times 10^{-8}$ atm cc/sec He

Ambient Operating Temperature

-40°F to 165°F / -40°C to 74°C

Flow Capacity

$C_v = 0.04$

$C_v = 0.30$ (optional)

Maximum Operating Torque

25 in-lbs / 2.8 N•m

MEDIA CONTACT MATERIALS

Body

316 Stainless Steel

Bonnet

Electroless Nickel Plated Brass

Seat

Teflon®

Spring Main Valve and Bias

316 Stainless Steel

Diaphragm

316 Stainless Steel

Remaining Parts

316 Stainless Steel

OTHER

Cleaning

CGA 4.1 and ASTM G93

Weight (without gauges)

2.75 lbs / 1.2 kg

Teflon® is a registered trademark of E.I du Pont de Nemours and Company.



TESCOM 44-4700 Series is an extremely sensitive, high purity, backpressure regulator for specialty, flammable and industrial gases for low pressure, and sub-atmospheric pressure control. Diffusion-resistant metal diaphragm seal ensures gas purity and leak integrity.

Applications

- Analytical systems
- Sample systems
- Pilot plants

Features and Benefits

- 316 Stainless Steel diaphragm provides metal-to-metal sealing integrity and good sensitivity
- Large sensing seat area ratio provides a low crack-to-reseat pressure differential and excellent repeatability
- Negative spring bias for vacuum systems
- Adjustable stop limits maximum outlet pressure
- NACE compliant designs are available

44-4700 Series Regulator Drawing

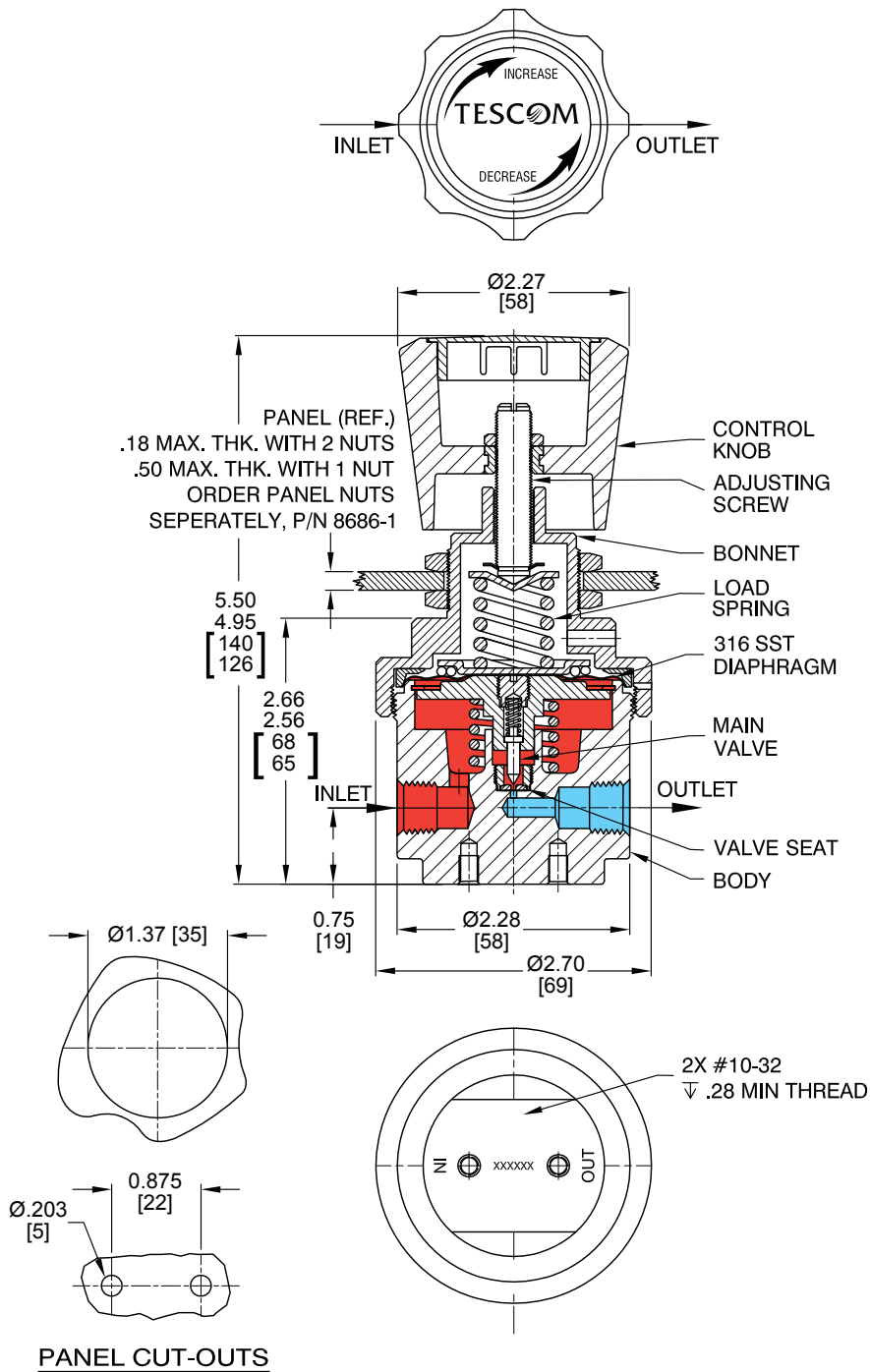

All dimensions are reference & nominal
Metric [millimeter] equivalents are in brackets

44-4700 Series Regulator Flow Chart

For more information on how to read flow curves, please refer to the Flow Curves and Calculations document (debul2007x012) in the TESCOM catalog or on www.tescom.com.

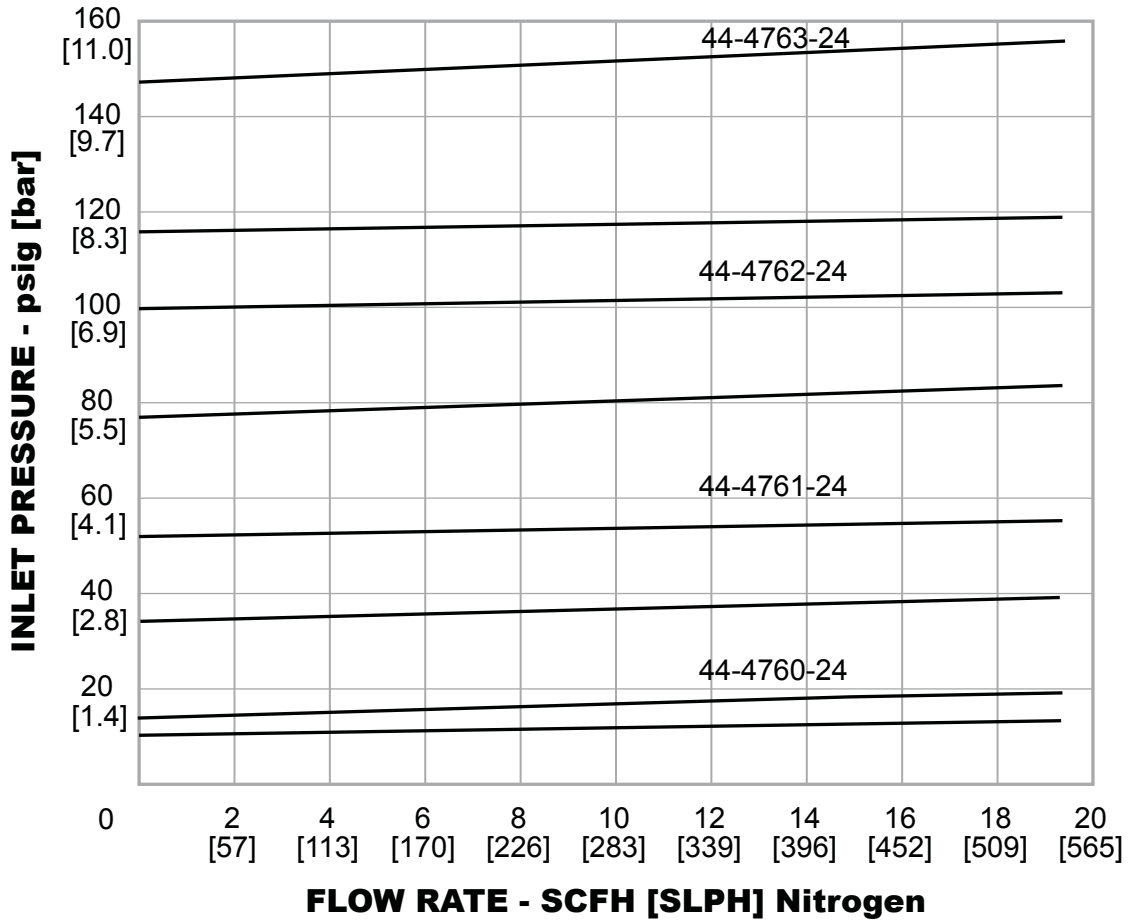

44-4700 Series Regulator Part Number Selector

Repair Kits, Accessories & Modifications may be available for this product. Please contact TESCOM for more information.

Example for selecting a part number:

44-47	6	0	-	2	4	
BASIC SERIES	BODY MATERIAL	INLET PRESSURE RANGES ¹		INLET AND OUTLET PORT TYPE	INLET AND OUTLET PORT SIZE	OPTIONS
44-47	6 – 316 Stainless Steel	0 – 50 mm Hg absolute - 15 psig / 1 bar 1 – 50 mm Hg absolute - 50 psig / 3.4 bar 2 – 50 mm Hg absolute - 100 psig / 6.9 bar 3 – 50 mm Hg absolute - 150 psig / 10.3 bar		1 – SAE 2 – NPTF 3 – MS33649 H – HPIC	4 – 1/4" 6 – 3/8"	-501 – C _v = 0.30
		<div style="border: 1px solid black; padding: 2px; width: fit-content;"> 1. 28" Hg = 50 mm Hg absolute </div>				