

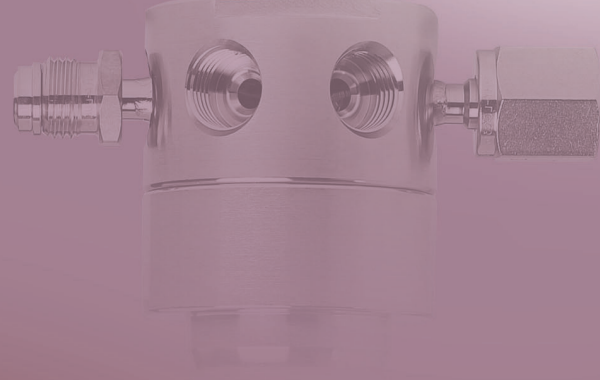

# DRA200 SERIES

ULTRA-HIGH PURITY

Positive Shutoff Regulator

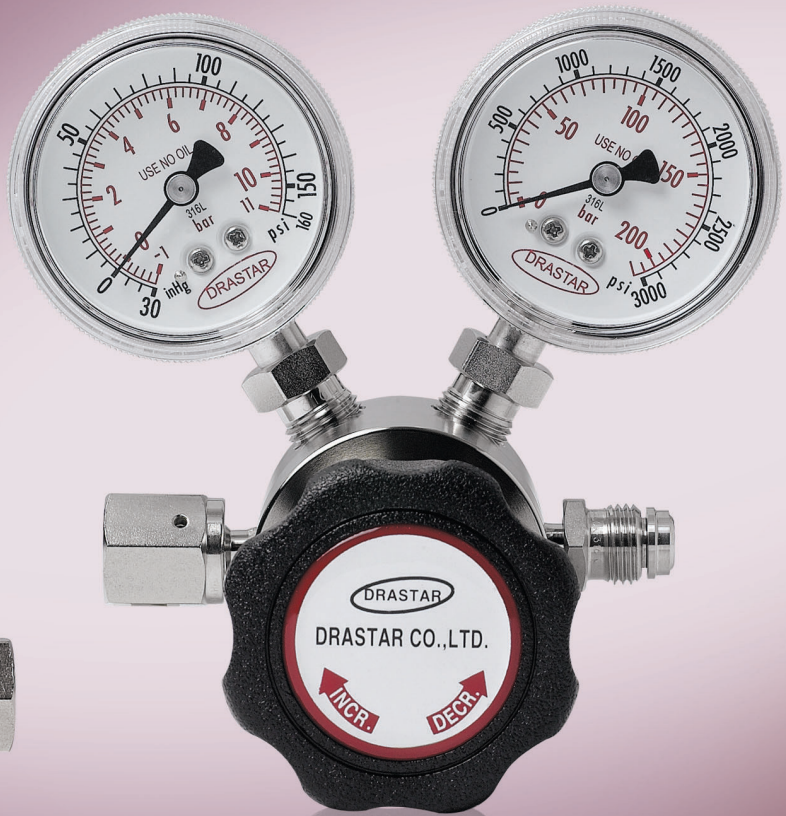



## DRA200 SERIES



## FUNCTIONAL SCHEMATIC

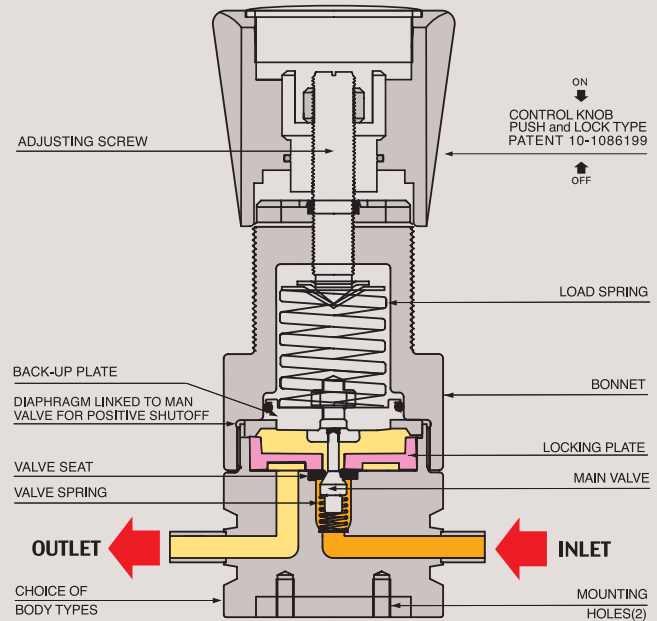

## ULTRA-HIGH PURITY POSITIVE SHUTOFF REGULATOR

### DRA200 SERIES (Tied Diaphragm Regulator)

DRA200(Tied type) 시리즈는 초고순도 반도체 제조용 Gas Cabinet, 특수 가스 라인, Valve Manifold Boxes, 기타 연구실 등에 사용하도록 고안된 Tied Diaphragm Pressure Reducing Regulator입니다. Tied type은 다이어프램과 메인 밸브를 연결시켜 이물질이 밸브 시트에 형성되더라도 압력 누설이 되지 않도록 최고의 안전성을 겸비한 방식으로 설계 고안된 제품입니다.

특히 독성 가스, 발화성 가스, 고부식성 가스등으로 다이어프램을 파열로부터 안전하게 보호하는 데 유용하며, 특허(10-0753280) 출원한 Locking-Plate 방식이 적용된 제품입니다. DRA200 시리즈는 이물질 발생을 방지하기 위해 DI water 세정과 E. P 10 Ra, 5 Ra급으로 내부표면을 처리하였습니다. DRA200시리즈는 조립, 용접, 실험과 세정까지의 모든 공정은 100-class와 10-class 크린룸에서 모든 작업이 이루어집니다. 모든 DRASTAR Regulators는 외부적인 진동과 가스배관 라인의 미세 진동 등으로 인하여 초기 셋팅 값이 스스로 변하는 현상을 완전히 해결한 드라스타만의 Push and Lock 타입의 조절 손잡이를 적용하여 사용하기에 더욱 편리합니다.

조절 손잡이를 누르면 셋팅값이 변하는 것을 방지하며, 손잡이를 앞으로 당기면 자유롭게 원하는 압력으로 다시 셋팅 할 수 있는 드라스타만의 특허 10-1086199 Push and Lock 타입의 레귤레이터입니다.

**DRA200 (tied type) series** is the tied-diaphragm pressure reducing regulator designed to use for gas cabinet for manufacturing the ultra-high pure semi-conductor, special gas line, valve manifold boxes, other laboratory, etc. Tied-diaphragm type regulator connects the diaphragm and main valve together which prevents pressure loss and so maximizes safety of the regulator. Specially, this model is very useful to protect the diaphragm from toxic gas, ignition gas, high-corrosive gases, etc., and patent-applied locking plate system is adopted (patent no. 10-0753280), too. In order to prevent generation of impurities, it is washed in DI water and the internal surface is treated to the grade of E.P. 10 Ra and 5 Ra. All processes of assembly, welding, testing and washing of DRA200 series are carried out and thoroughly managed in the 100-class and 10-class clean

room. DRASTAR regulators are designed and manufactured for easier operation by equipping with the DRASTAR's own developed push and lock type handle which completely prevents the self-change of pre-set value which can be caused by the vibration from outside or minute vibration at the gas pipeline. You can prevent the self-changing of pre-set value just by pushing the handle and reset the value freely by drawing the handle. DRASTAR has created and applied patent for this push and lock system for DRASTAR regulators (patent number 10-1086199).

### Features

- Tied Diaphragm design for positive shut-off
- All semiconductor gas industry
- For toxic gas
- For pyrophoric gas
- For high corrosive gas
- For protecting the diaphragm from rupturing
- Locking-Plate Seal system(Patent No : 10-0753280)

### 권장 사항

각 제품들은 최고의 안전성과 쉬운 조작성을 고려하여 제작되었습니다. 그러나 가장 안전하고 효율적인 Regulator 사용을 위해서는 실제 사용 압력을 각각 모델의 사용 압력에 25%~75% 이내에서 사용하면 가장 이상적인 압력을 사용할 수 있습니다. 정밀하고 원활한 동작과 제품의 수명 연장을 위해서는 위의 범위 내에서 사용하기를 적극 권장합니다.

### Recommendations to Use

Each product is manufactured since being taken into consideration of the best safety and easy manipulation. However in order to use the regulator in most safe and effective way, you are recommended to use the actual pressure within the range of its 25% ~ 75%. For making precise, smooth movement and to prolong product life, strongly recommended to make a use within above mentioned range.

**REFERENCE**

This catalogue is printed as of January 2016, and the dimensions and/or specifications in this catalogue can be changed without prior notice in the course of constant upgrading and improvement of our products.

**INSTALLATION DIMENSIONS**

**METRIC EQUIVALENTS ARE IN PARENTHESES**

**GAUGE PORT OPTIONS**

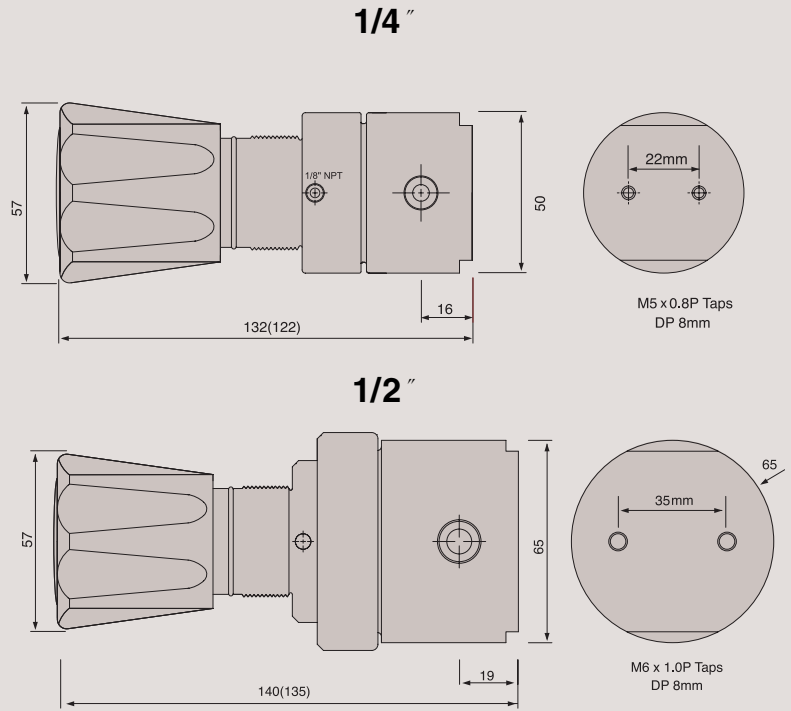
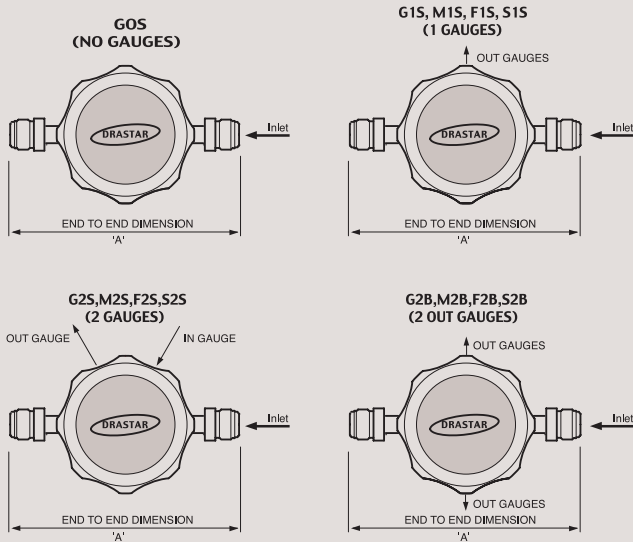

**ORDERING INFORMATION**

**DRA200 - A 025 S - H P S - 4MS - G0S**

**BASIS SERIES**

**BODY MATERIAL**

- A = 316L Bright Annealed B.A
- B = 316L Electropolish 10Ra
- C = 316L Internal Electropolish 10Ra
- D = 316L Electropolish VAR(P.E.P) 10Ra
- E = 316L Electropolish VAR(P.E.P) 5Ra

**OUTLET PRESSURE RANGE**

- 025 = 1-25psi (.1-1.7bar)
- 050 = 1-50psi (.1-3.5bar)
- 100 = 1-100psi (.1-7bar)
- 250 = 1-250psi (.2-17bar)

**DIAPHRAGM MATERIAL**

- S = STS 316L
- H = Hastelloy-C

**MAX. INLET PRESSURE**

- H = 3500psi(238bar)
- L = 600psi(41bar)

**SEAT MATERIAL**

- P = PCTFE
- T = Teflon
- V = Vespel

**GAUGE PORTS OPTIONS**

- |                           |                              |
|---------------------------|------------------------------|
| G0S = None ..... 0        | F1S = 1/4" Female Sw..... 1  |
| G1S = 1/4" H.P.I.C..... 1 | F2S = 1/4" Female Sw..... 2  |
| G2S = 1/4" H.P.I.C..... 2 | F2B = 1/4" Female Sw..... 2  |
| G2B = 1/4" H.P.I.C..... 2 | S1S = 1/4" Fixed Male .... 1 |
| M1S = 1/4" Male Sw..... 1 | S2S = 1/4" Fixed Male .... 2 |
| M2S = 1/4" Male Sw..... 2 | S2B = 1/4" Fixed Male .... 2 |
| M2B = 1/4" Male Sw..... 2 |                              |

**INLET / OUTLET PORTS SIZE**

- |  | Type "A" ±1.0mm |
|--|-----------------|
| 4HP = 1/4" H.P.I.C                         |                 |
| 4MS & 4FS = 1/4" Male, Female Sw. ....     | 94mm            |
| 4FL & 4ML = 1/4" Male, Female Sw. ....     | 00mm            |
| 8MS & 8FS = 3/8" Male, Female Sw. ....     | 120mm           |
| 8FL & 8ML = 3/8" Male, Female Sw. ....     | 000mm           |
| 2MS & 2FS = 1/2" Male, Female Sw. ....     | 140mm           |
| 2FL & 2ML = 1/2" Male, Female Sw. ....     | 000mm           |
| 3MS & 3FS = 3/4" Male, Female Sw. ....     | 160mm           |
| 3FL & 3ML = 3/4" Male, Female Sw. ....     | 000mm           |
| 4IMF = In 1/4" Male Out 1/4" Female .....  | 94mm            |
| 4IFM = In 1/4" Female Out 1/4" Male .....  | 94mm            |
| 2IMF = In 1/2" Male Out 1/2" Female .....  | 140mm           |
| 2IFM = In 1/2" Female Out 1/2" Male .....  | 140mm           |
| 2IMFL = In 1/2" Male Out 1/2" Female ..... | 000mm           |
| 2IFML = In 1/2" Female Out 1/2" Male ..... | 000mm           |
| 4TS = 1/4" Tube Stubs .....                | 94mm            |
| 8TS = 3/8" Tube Stubs .....                | 94mm            |
| 2TS = 1/2" Tube Stubs .....                | 120mm           |
| 3TS = 3/4" Tube Stubs .....                | 120mm           |

**FLOW CAPACITY**

- S = Cv 0.06 Standard (Inlet 3000psi) (1/4")
- O = Cv 0.2 Optional (Inlet 500psi) (1/4")
- S = Cv 0.2 Optional (3/8")
- S = Cv 0.5 Optional (1/2")
- O = Cv 1.0 Optional (1/2")
- S = Cv 1.2 Standard (3/4")



## FLOW CHART

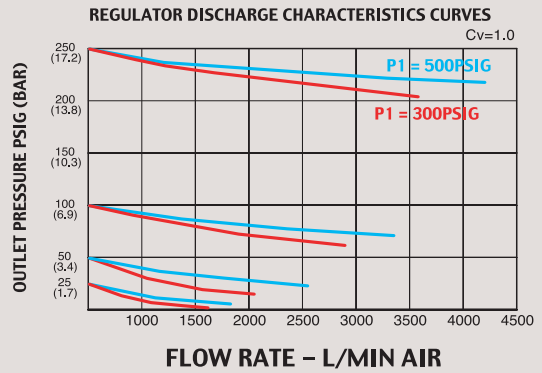
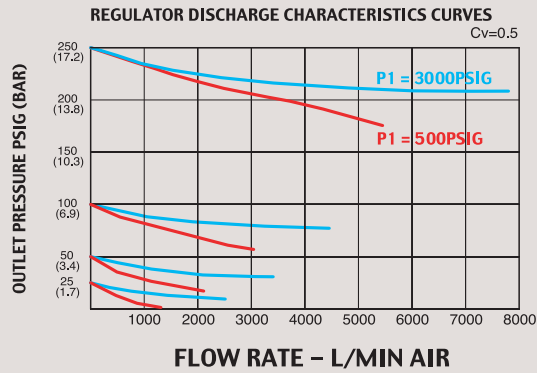
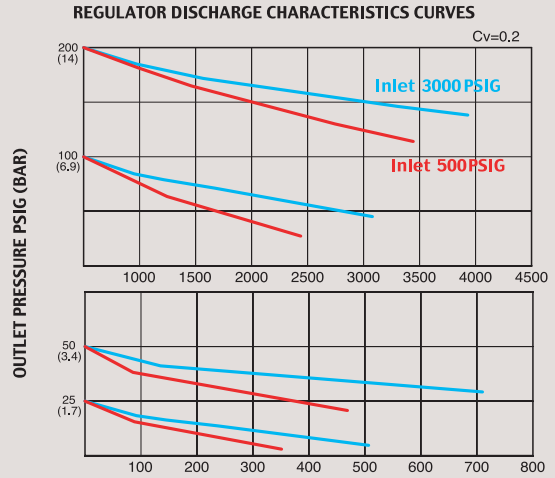
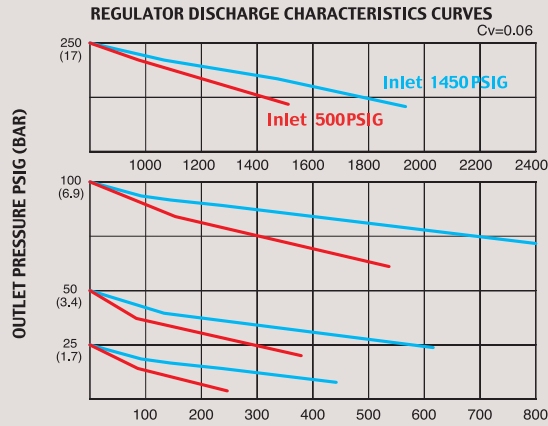

### DRA200 Series 1/4"

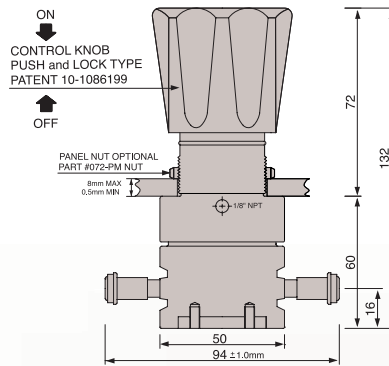
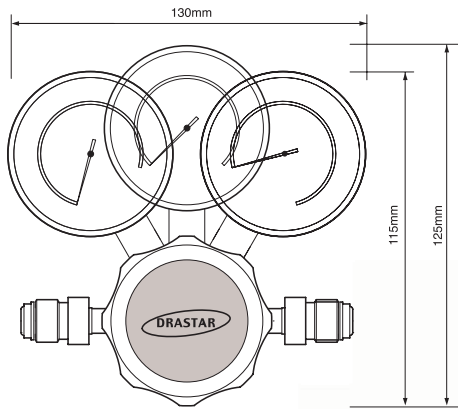

### DRA200 Series 1/4" & 3/8"

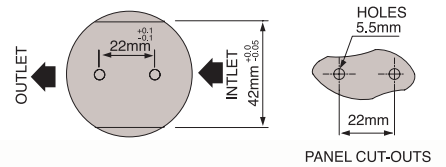

### DRA200 Series 1/2"

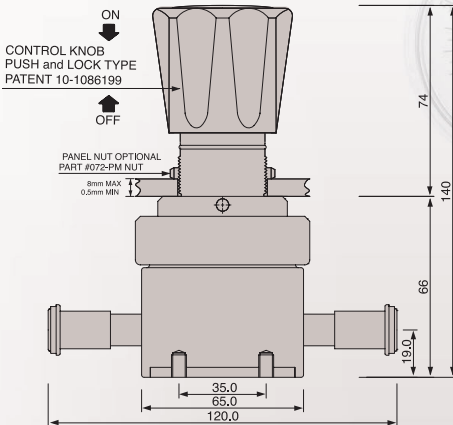
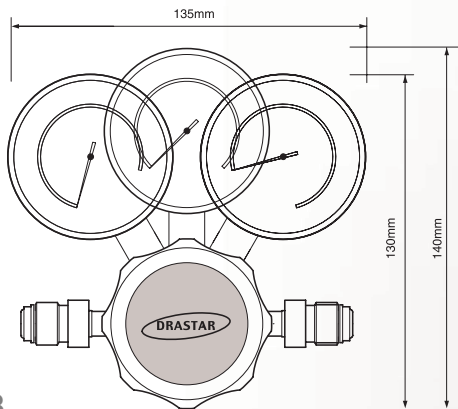

### DRA200 Series 1/2" & 4/3"

