

Datasheet FG-111B

Mass Flow Meter for Gases

> Introduction

Bronkhorst® EL-FLOW® Prestige model FG-111B is a High Performance Multi-Fluid, Multi-Range Mass Flow Meter (MFM) offering precise measurement of virtually all conventional process gases. The MFM consists of a thermal mass flow sensor and a microprocessor based pc-board with signal and fieldbus conversion and a PID controller for optional mass flow control by means of a separately mounted control valve. The mass flow, expressed in normal litres or millilitres per minute or per hour, is provided as analog signal or digitally via RS232 or fieldbus. EL-FLOW® Prestige features a programmable pin (pin 5) at the 9-pin sub-D connector for customized I/O configurations. The flow range and wetted materials are determined depending of the type of gas and the process conditions of the application.



EL-FLOW Prestige Mass Flow Meter model FG-111B

> Technical specifications

Measurement / control system

Accuracy (incl. linearity) (Based on actual calibration)	: $\pm 0,5\%$ Rd plus $\pm 0,1\%$ FS
Repeatability	: $< \pm 0,2\%$ Rd
Turndown	: 1 : 150 (in analog mode 1:50)
Multi Gas / Multi Range gases	: embedded gas data for Air, N ₂ , Ar, H ₂ , O ₂ , CO, CO ₂ , He, CH ₄ , SiH ₄ , NH ₃ , C ₂ H ₂ , C ₂ H ₄ , C ₂ H ₆ , C ₃ H ₆ #2 (propene), C ₂ F ₆ , C ₃ H ₈ , NF ₃ , N ₂ O, H ₂ S, Cl ₂ , SF ₆ , NO, Kr, Xe, plus any mixture of max. 5 of these gases
Temperature range	: -10...+70°C
Temperature sensitivity	: zero: $< \pm 0,02\%$ FS/°C; span: $< \pm 0,025\%$ Rd/°C
Pressure sensitivity	: $< 0,15\%$ Rd/bar typical N ₂ ; $< 0,2\%$ Rd/bar N ₂ (incl. pressure correction option)
Leak integrity (outboard)	: tested $< 2 \times 10^{-9}$ mbar l/s He
Attitude sensitivity	: max. error at 90° off horizontal 0,07% FS at 1 bar, typical N ₂
Warm-up time	: 30 min. for optimum accuracy

Although all specifications in this datasheet are believed to be accurate, the right is reserved to make changes without notice or obligation.

Mechanical parts

Material (wetted parts)	: stainless steel 316L or comparable
Pressure rating	: 100 bar abs
Process connections	: compression type or face seal male
Seals	: standard : Viton®; options: EPDM, Kalrez®
Ingress protection (housing)	: IP40

Electrical properties

Power supply	: +15...24 Vdc $\pm 10\%$
Power consumption	: Supply at voltage I/O at current I/O
(based on N/C valve)	15 V 69 mA 92 mA
	24 V 45 mA 63 mA
Extra for fieldbus:	PROFIBUS DP: add 53 mA (15 V supply) or 30 mA (24 V supply)
(if applicable)	PROFINET: add 76 mA (15 V supply) or 48 mA (24 V supply)
	EtherCAT®: add 66 mA (15 V supply) or 41 mA (24 V supply)
	DeviceNet™: add 48 mA (24 V supply)
Analog output (0...100%)	: 0...5 (10) Vdc, min. load impedance > 2 k Ω ; 0 (4)...20 mA (sourcing), max. load impedance < 375 Ω
Analog setpoint (0...100%)	: 0...5 (10) Vdc, min. load impedance > 100 k Ω ; (for MFM + control valve) 0 (4)...20 mA, load impedance ~ 250 Ω
Digital communication	: standard RS232; options: PROFIBUS DP, DeviceNet™, EtherCAT, PROFINET, Modbus RTU/ASCII, FLOW-BUS

> Ranges (based on N₂)

Model	minimum	maximum
FG-111B	0,14...7 ml _n /min	0,16...20 l _n /min

Intermediate ranges are available

> Model number identification

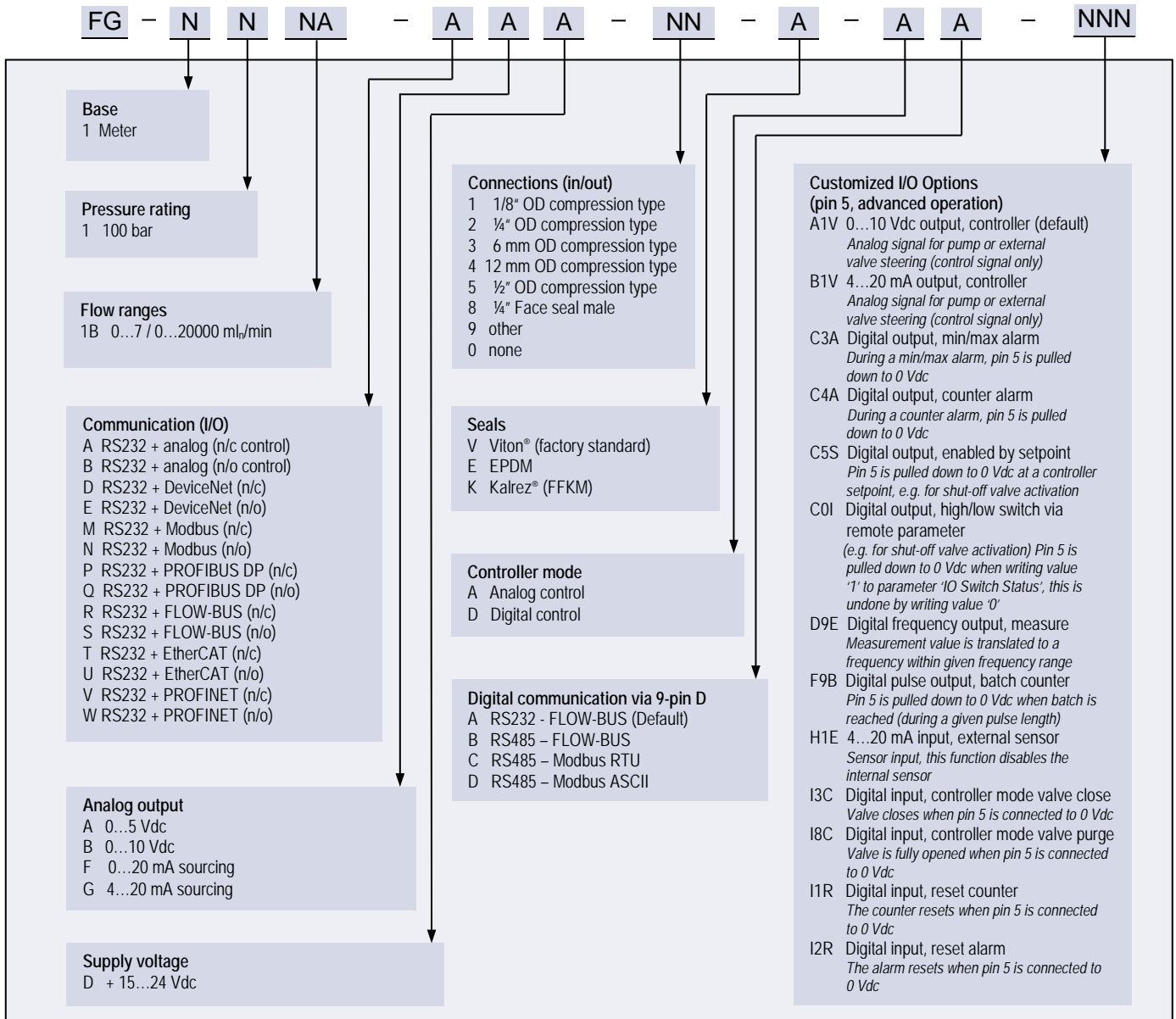

> Thermal mass flow measuring principle

The heart of the thermal mass flow meter/controller is the sensor, that consists of a stainless steel capillary tube with resistance thermometer elements. A part of the gas flows through this bypass sensor, and is warmed up heating elements. Consequently the measured temperatures T_1 and T_2 drift apart. The temperature difference is directly proportional to mass flow through the sensor. In the main channel Bronkhorst applies a patented laminar flow element consisting of a stack of stainless steel discs with precision-etched flow channels. Thanks to the perfect flow-split the sensor output is proportional to the total mass flow rate.

$$\Delta T = k \cdot C_p \cdot \dot{m} \quad \Delta T = T_2 - T_1 \text{ in Kelvin} \quad C_p = \text{specific heat} \quad \dot{m} = \text{mass flow}$$

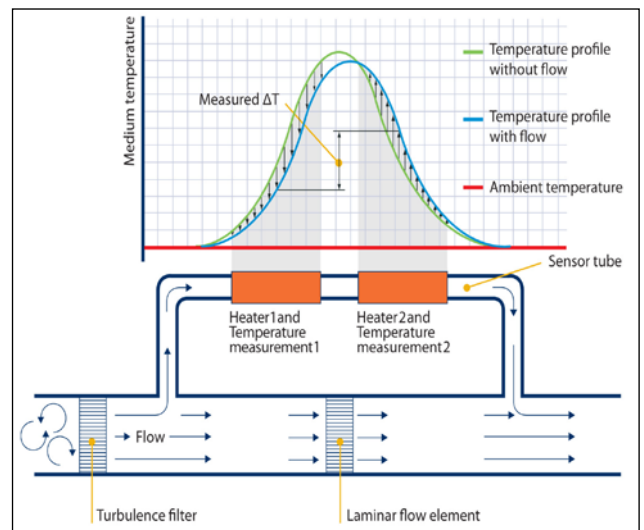

> Hook-up diagram for analog or RS232 communication

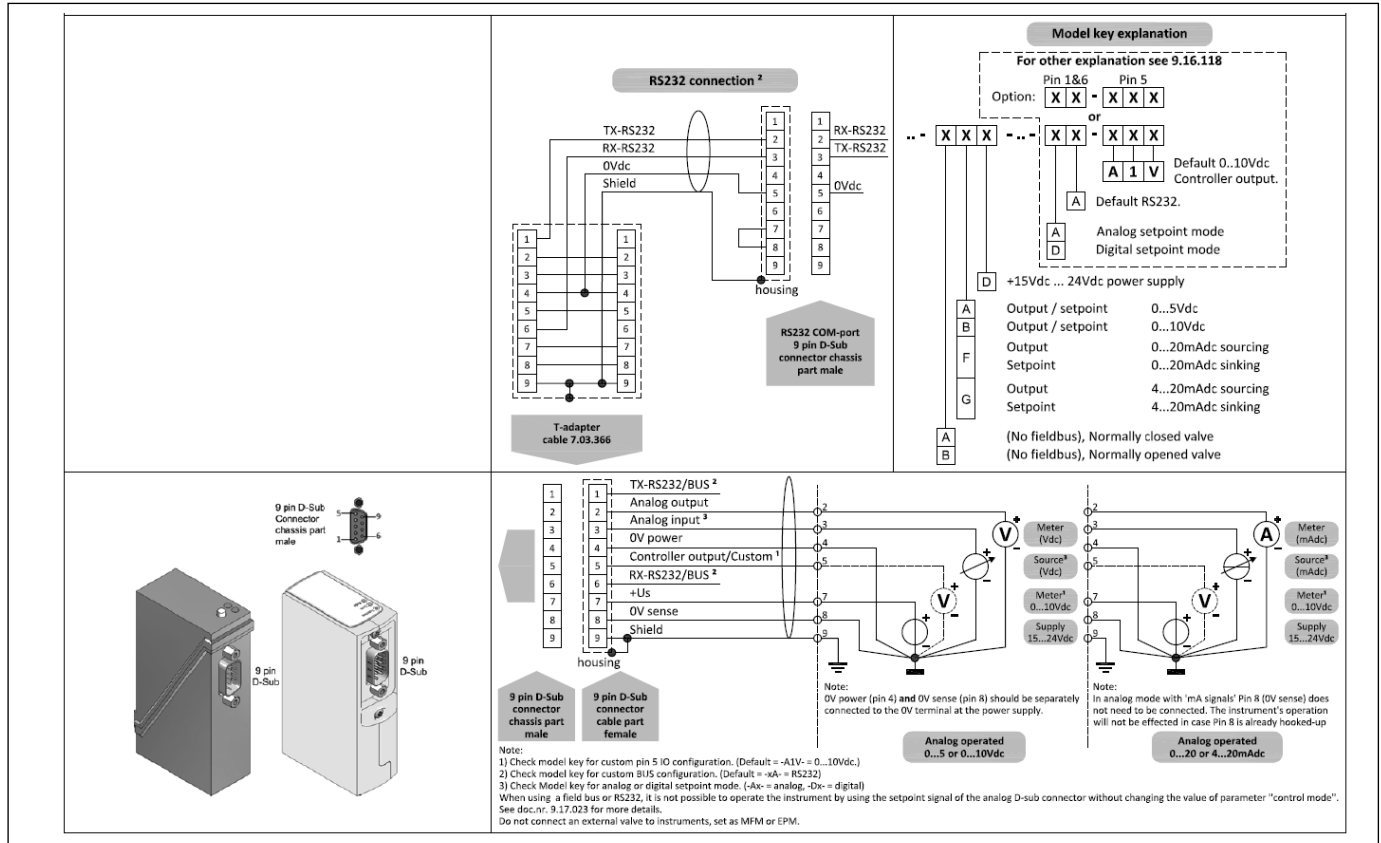

> Hook-up diagrams for fieldbus communication

For the available fieldbus options we refer to the various hook-up diagrams as indicated below. If you are viewing this datasheet in digital format, you may use the hyperlink to each of the drawings. Otherwise please visit the download section on www.bronkhorst.com or contact our local representatives.

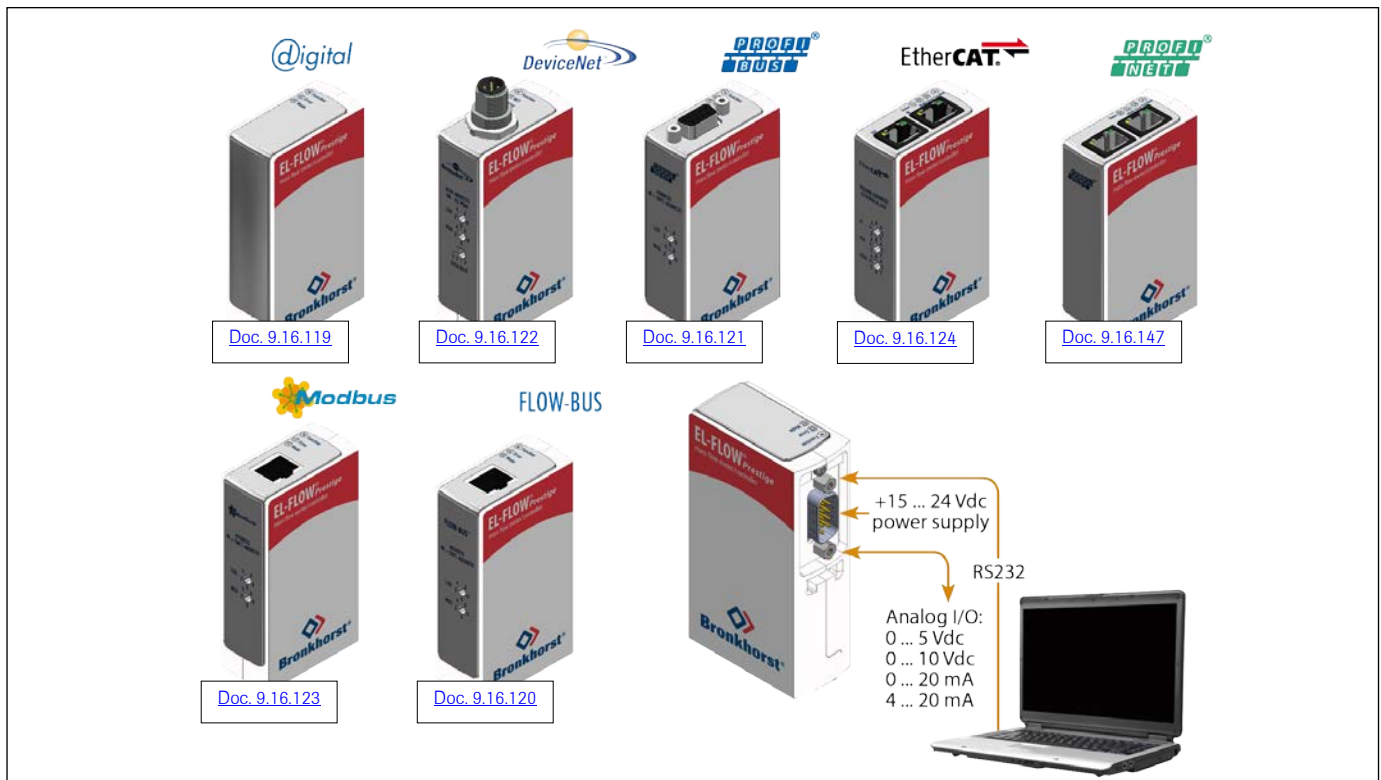

> Dimensions (mm) and weight (kg)

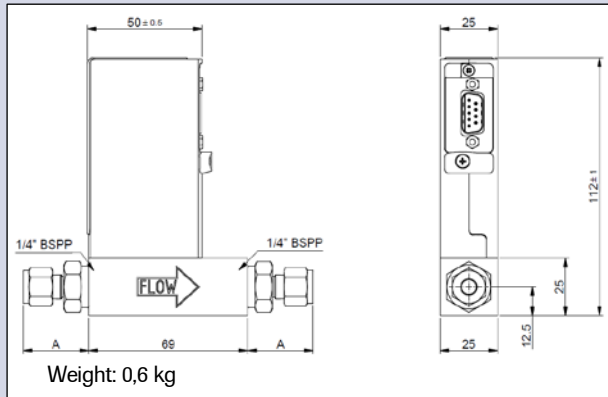

Dimension table adapters (RS-type)

Compression type	1/4" BSPP	
		Size A
adapter 3 mm OD		26.1
adapter 6 mm OD		28.4
adapter 8 mm OD		29.4
adapter 10 mm OD		30.2
adapter 12 mm OD		32.5
adapter 1/8" OD		26.1
adapter 1/4" OD		28.4
adapter 3/8" OD		29.9
adapter 1/2" OD		32.7
Face-seal male	Size A	
adapter 1/4" inlet		23.2

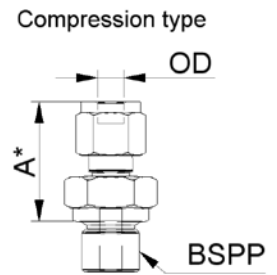

*) Dimension A is typical finger-tight.

> Options and accessories

<ul style="list-style-type: none"> - Free configuration software for Multi-Gas / Multi-Range functionality. - Free software support for operation, monitoring, optimizing or to interface between digital instruments and windows software. 	
<ul style="list-style-type: none"> - IN-LINE filters for protection against particulates 	
<ul style="list-style-type: none"> - BRIGHT compact local Readout/Control modules - E-8000 Power Supply/Readout systems 	
<ul style="list-style-type: none"> - Interconnecting cables for power and analog/digital communication - PiPS Plug-in Power Supply 	

> Alternatives

<ul style="list-style-type: none"> - EL-FLOW Prestige Mass Flow Controller (MFC), model FG-201CV, ranges from 0,14-7 ml_r/min up to 0,4-20 l_r/min 	
<ul style="list-style-type: none"> - EL-FLOW Select series Mass Flow Meter (MFM), model F-111B, ranges from 0,16-8 ml_r/min up to 0,16-25 l_r/min 	
<ul style="list-style-type: none"> - Metal sealed MFM for Semiconductor or other high purity applications - Mass Flow Meter for standardised modular platform systems (top-mount version) 	