

Datasheet F-202AI

Mass Flow Controller for Gases

> Introduction

Bronkhorst® model F-202AI Mass Flow Controllers (MFCs) are suited for precise control of virtually all conventional process gases. The MFC consists of a thermal mass flow sensor, a precise control valve and a microprocessor based PID controller with signal and fieldbus conversion. As a function of a setpoint value, the flow controller swiftly adjusts the desired flow rate. The IN-FLOW model is of rugged design (IP65) for use in industrial environments or even Zone 2 hazardous areas, with optional ATEX Cat. 3 approval. The mass flow, expressed in normal litres per minute or per hour, is provided as analog signal or digitally via RS232 or fieldbus. The flow range, wetted materials and orifice size for the control valve are determined depending of the type of gas and the process conditions of the application.



IN-FLOW Mass Flow Controller model F-202AI

> Technical specifications

Measurement / control system

Accuracy (incl. linearity) (Based on actual calibration)	: $\pm 0,5\%$ Rd plus $\pm 0,1\%$ FS
Turndown	: 1 : 50 (in digital mode up to 1:187,5)
Multiple fluid capability	: storage of max. 8 calibration curves
Repeatability	: $< \pm 0,2\%$ Rd
Settling time (controller)	: 2...4 seconds
Control stability	: $\leq \pm 0,1\%$ FS
Kv-value	: 0,04...0,4
Temperature range	: -10...+70°C for ATEX cat. 3 0...50°C
Temperature sensitivity (nominal range)	: zero: $< \pm 0,05\%$ FS/°C; span: $< \pm 0,05\%$ Rd/°C
Pressure sensitivity	: 0,1% Rd/bar typical N ₂ ; 0,01% Rd/bar typical H ₂
Leak integrity (outboard)	: $< 2 \times 10^{-9}$ mbar l/s He
Attitude sensitivity	: max. error at 90° off horizontal 0,2% FS at 1 bar, typical N ₂
Warm-up time	: 30 min. for optimum accuracy 2 min. for accuracy $\pm 2\%$ FS

Mechanical parts

Material (wetted parts)	: stainless steel 316L or comparable
Pressure rating	: 64 bar abs
Process connections	: compression type or face seal male
Seals	: standard : Viton; options: EPDM, Kalrez
Ingress protection (housing)	: IP65

Although all specifications in this datasheet are believed to be accurate, the right is reserved to make changes without notice or obligation.

Electrical properties

Power supply	: +15...24 Vdc $\pm 10\%$
Power consumption	: max. 320 mA; add 50 mA for Profibus, if applicable
Analog output (0...100%)	: 0...5 (10) Vdc, min. load impedance $> 2 \text{ k}\Omega$; 0 (4)...20 mA (sourcing), max. load impedance $< 375 \text{ }\Omega$
Analog setpoint (0...100%)	: 0...5 (10) Vdc, min. load impedance $> 100 \text{ k}\Omega$; 0 (4)...20 mA, load impedance $\sim 250 \text{ }\Omega$
Digital communication	: standard RS232 ; options: PROFIBUS DP, DeviceNet™, Modbus-RTU/ASCII, FLOW-BUS

> Ranges (based on Air)

Model	minimum	nominal	maximum
F-202AI-M10	0,8...40 l _n /min	0,8...100 l _n /min	0,8...150 l _n /min
F-202AI-M20	1,4...70 l _n /min	1,4...200 l _n /min	1,4...250 l _n /min

Intermediate ranges are available

> Model number identification

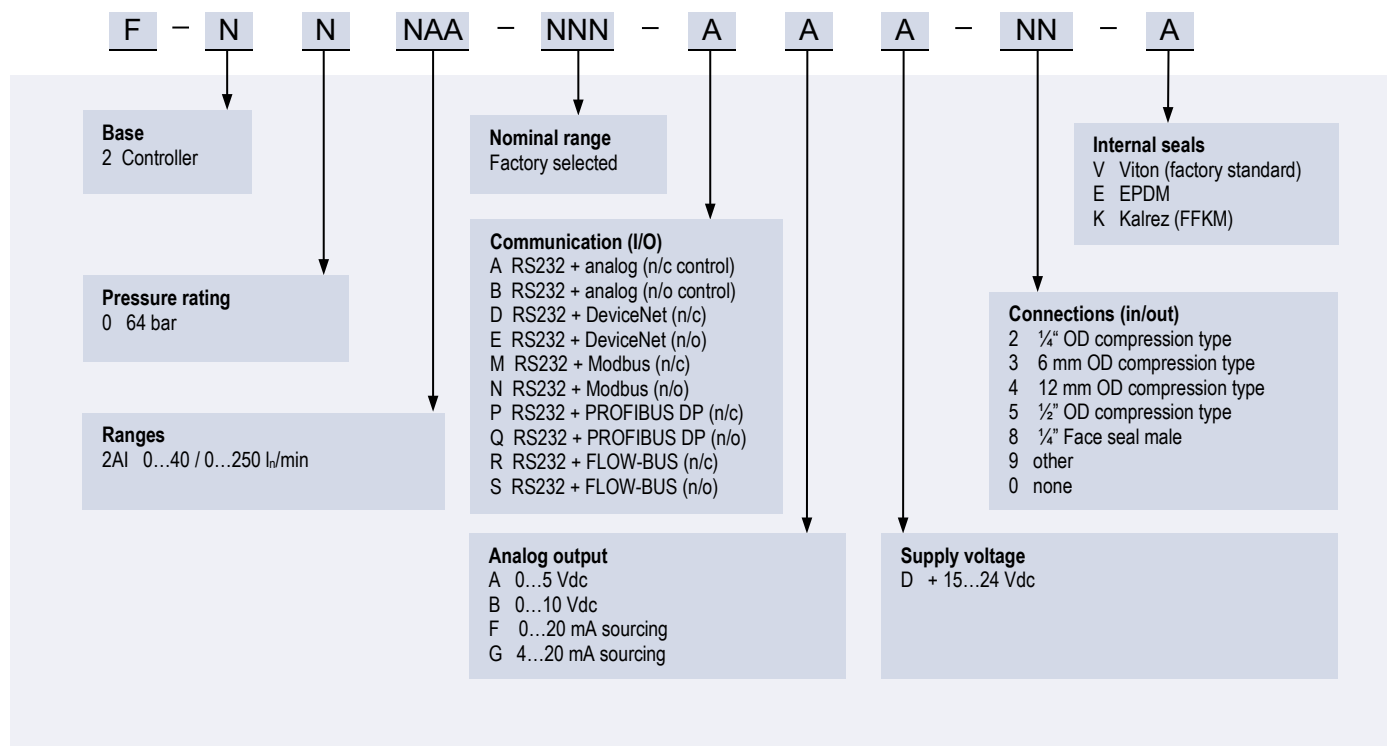

> Thermal mass flow measuring principle

The heart of the thermal mass flow meter/controller is the sensor, that consists of a stainless steel capillary tube with resistance thermometer elements. A part of the gas flows through this bypass sensor, and is warmed up heating elements. Consequently the measured temperatures T_1 and T_2 drift apart. The temperature difference is directly proportional to mass flow through the sensor. In the main channel Bronkhorst High-Tech applies a patented laminar flow element consisting of a stack of stainless steel discs with precision-etched flow channels. Thanks to the perfect flow-split the sensor output is proportional to the total mass flow rate.

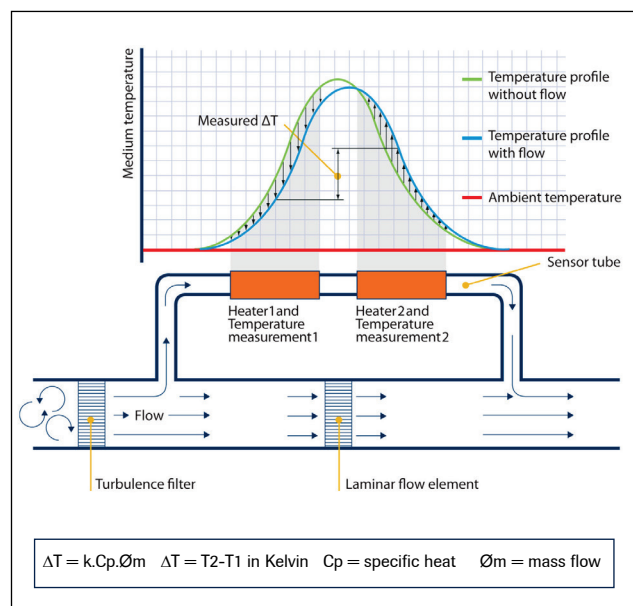

Functional scheme of the thermal mass flow sensor

> State of the art digital design

Today's IN-FLOW series are equipped with a digital pc-board, offering high accuracy, excellent temperature stability and fast response (settling times t_{98} down to 500 msec). The basic digital pc-board contains all of the general functions needed for measurement and control. In addition to the standard RS232 output the instruments also offer analog I/O. Furthermore, an integrated interface board provides DeviceNet™, PROFIBUS DP, Modbus-RTU/ASCII or FLOW-BUS protocols.

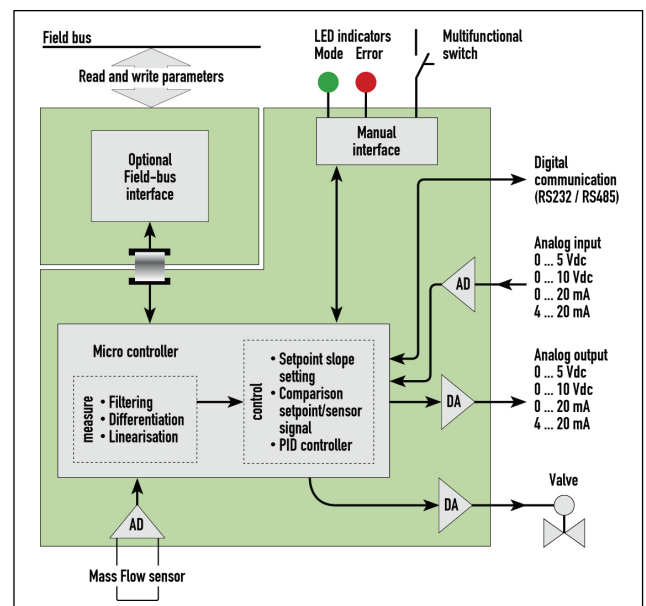

Functional scheme of the digital PC-board

> Hook-up diagram for analog or RS232 communication

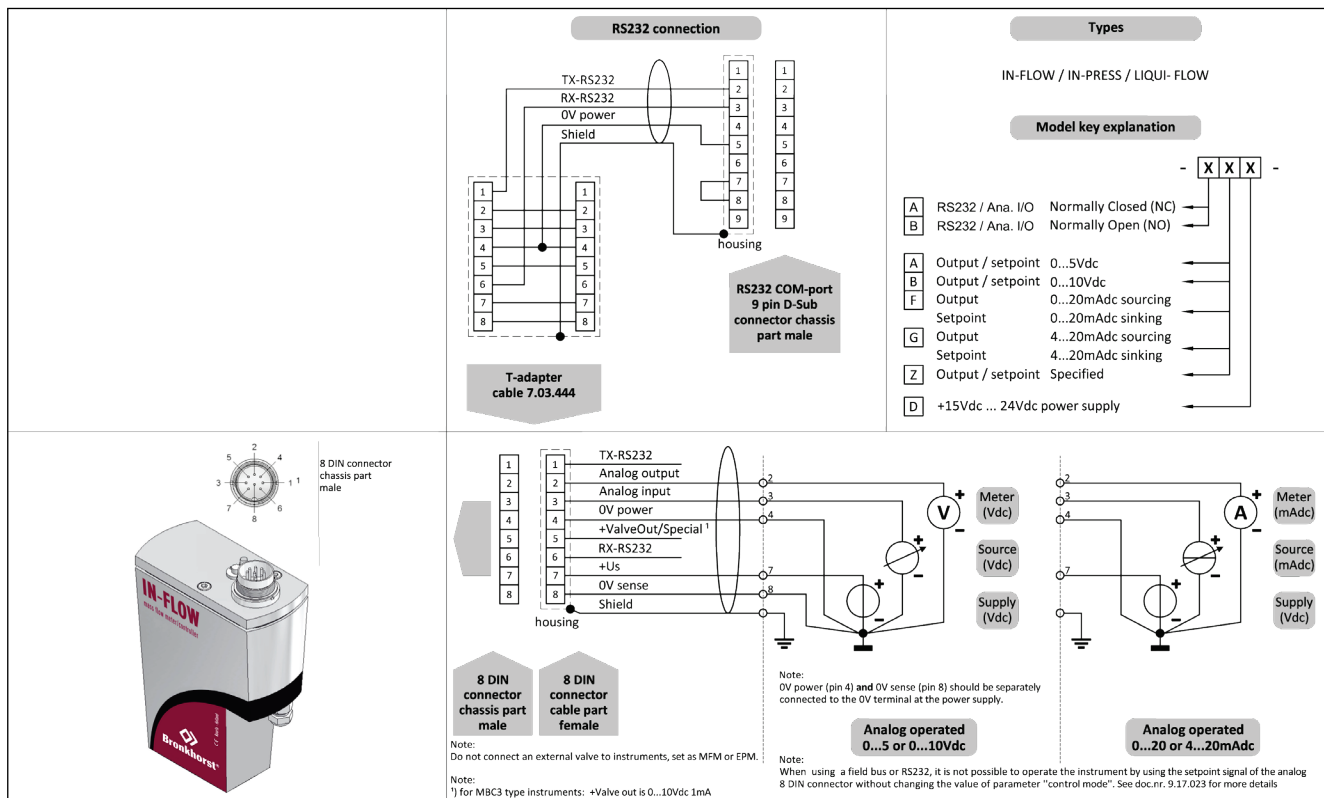

> Hook-up diagrams for fieldbus communication

For the available fieldbus options we refer to the various hook-up diagrams as indicated below. If you are viewing this datasheet in digital format, you may use the hyperlink to each of the drawings. Otherwise please visit the download section on www.bronkhorst.com or contact our local representatives.

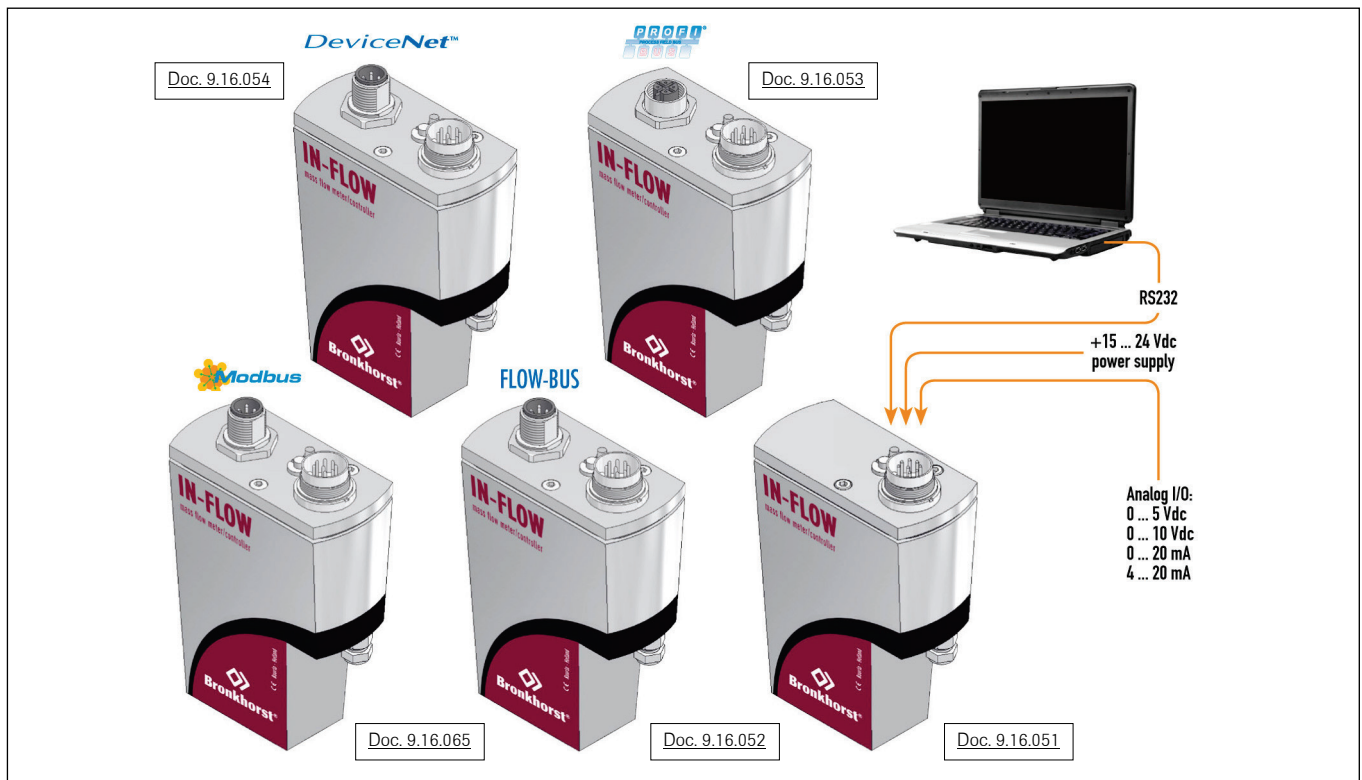

> Dimensions (mm) and weight (kg)

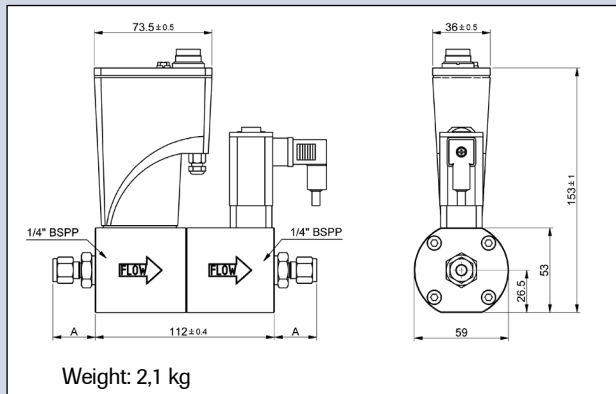



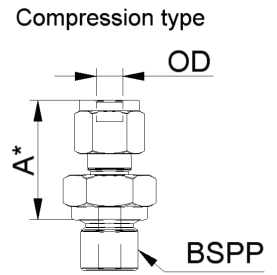

Dimension table adapters (RS-type)

Compression type		1/4"BSPP
		Size A
adapter 6 mm	OD	28.4
adapter 8 mm	OD	29.4
adapter 10 mm	OD	30.2
adapter 12 mm	OD	32.5
adapter 1/4"	OD	28.4
adapter 3/8"	OD	29.9
adapter 1/2"	OD	32.7
Face-seal male		Size A
adapter 1/4"	inlet	23.2



*) Dimension A is typical finger-tight.

> Options and accessories

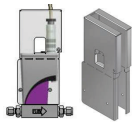
- Free software support for operation, monitoring, optimizing or to interface between digital instruments and windows software.	
- IN-LINE filters for protection against particulates	
- BRIGHT compact local Readout/Control module - E-8000 Power Supply	
- Interconnecting cables for power and analog/digital communication - PiPS Plug-in Power Supply	
- Optional ATEX Zone 2 Cat. 3 protection. Hereto we will furnish extra cover(s) for mechanical impact protection (see pictures), including applicable certificate(s).	

> Alternatives

- LOW-ΔP-FLOW series MFC or MFM with bellows operated control valve (F-004 series) for low pressure drop applications or corrosive gas service	
- IN-FLOW ^{CTA} direct (no by-pass), industrial (IP65) Mass Flow Controller	